

Foreword

Thank you for using the AE series of high-performance high torque vector inverter.

New AE200H series is a general current vector control inverter integrated with the performance and features in a high degree.

AE200H with industry-leading drive performance and functionality control, using unique current vector control algorithm can efficiently drive induction motor and synchronous motor to achieve high accuracy, high torque and high-performance control.

Customer success, Market Service! AE200H in terms of performance and control are worthy of trust!

This guide explains how to properly use AE200H series inverter. Before using (installation, operation, maintenance, inspection, etc.), be sure to carefully read the instructions. Understanding of product safety precautions before using this product.

General notes
<ul style="list-style-type: none">● This manual due to product improvement, specifications change, as well as to the instructions of their ease of use will be appropriate changes. We will update the information number of instructions, issued a revised edition.● Due to damage to or loss need to order the manual, please contact AE or AE200H agents to order it as per the information number on the cover.● This icon in the instructions with the products you ordered may be different, please refer to the specific documentation for products supplied.

Definition of security

In this manual, safety issues the following two categories:



Warning: Due to the dangers posed against the required operation, may result in serious injury and even death;



Caution: Due to the dangers posed against the required operation, may lead to moderate harm or minor injuries, and damage to the equipment;

Installation, commissioning and maintenance of the system, please carefully read this chapter (safety precautions), follow the required safety precautions to operate. In case of any injuries and losses caused as a result of illegal operations , that is nothing to do with AE200H.

Safety precautions

Before Installation



Warning

Do not install inverter finding the control system with water in, or inverter with missing parts or damaged parts.

Please do not install inverter when the packing list is not consistent with the physical name.



Warning

Carefully handled when loading, otherwise it may damage the inverter.

Please don't use the damaged driver or missing parts inverter, there may be risk of injury.

Do not touch components of the control system, otherwise it will cause danger of static electricity.

During Installation



Warning

Mount the inverter on incombustible surface like metal, and keep away from flammable substances. Otherwise it may cause fire.

Do not twist the mounting bolt of the equipment, especially the screw bolt marked in RED.

Prohibit the use in the dangerous environment where inflammable or combustible or explosive gas, liquid or solid exists. Or it may cause electric shock or fire.



Caution

Do not drop the conducting wire stub or screw into the inverter. Otherwise ,it may cause damage to the inverter.

Please install the inverter at the place of less direct sunlight and vibration.

Please mind the location of its installation when more than two inverters are installed in one cabinet, so that radiation effect is promised.

During Wiring



Warning

Operation shall be performed by the professional engineering technician. Otherwise there will be unexpected danger.

There shall be circuit breaker between the inverter and power supply. Otherwise, there may be fire.

Make sure the power is disconnected prior to the connection. Otherwise there will be danger of electric shock.

The earth terminal shall be earthed reliably. Otherwise there may be danger of electric shock.



Warning

Please don't put the power line and the signal line from the same pipeline. when operating wiring, please make power line and signal line apart above 30cm.

The encoder must use shielded cable, and the shield must ensure that a single side of a reliable ground!

Do not connect the input power cable to the output terminals(U/T1、V/T2、W/T3).Attention to the terminals of the mark and do not make wrong connection. Otherwise it may damage the inverter.

The brake resistor cannot be directly connected between the DC bus terminals (DC+)、(DC-). Otherwise it may cause fire.

Ensure the wiring meet the EMC requirements and the local safety standard.

The wire size shall be determined according to the manual. Otherwise, accident may be caused!

Before Power-on:



Caution

Any part of the inverter need not to carry on pressure test,which has been done before leaving factory.Or accident may be caused.

Please confirm whether the power voltage class is consistent with the rated voltage of the inverter and the Input terminal (R/L1、S/L2、T/L3) and Output terminal(U/T1、V/T2、W/T3)cable connecting positions are correct, and check whether the external circuit is short circuited and whether the connecting line is firm, otherwise it may damage the inverter.

Do not frequently turn ON/OFF power .If continuously ON/OFF power is needed, please make sure the time interval more than 1 minute.



Caution

The cover must be well closed prior to the inverter power-on. Otherwise electric shock may be caused!

All the external fittings must be connected correctly in accordance with the circuit provided in this manual.Or accident may occur.

Upon Power-on



Warning

Do not open the cover of the inverter upon power-on.Otherwise there will be danger of electric shock!

Do not touch the inverter and its surrounding circuit with wet hand. Otherwise there will be danger of electric shock.

Do not touch the inverter terminals (including control terminal). Otherwise there will be danger of electric shock.

At power-on, the inverter will perform the security check of the external stong-current circuit automatically. Thus, at this time please do not touch the terminals U/T1、V/T2、W/T3, or the terminals of motor, otherwise there will be danger of electric shock.

If the parameter identification is required, pay attention to the danger of injury arising from the rotating motor. Otherwise accident may occur.

Do not change the factory settings at will. Otherwise it may damage the equipment.

During the Operation



Warning

Do not touch the fan, heat sink or discharge resistor to sense the temperature. Otherwise, you may get burnt.

Detection of signals during the operation shall only be conducted by qualified technician. Otherwise, personal injury or equipment damage may be caused.



Cautions

Do not control run/stop by using contactor. Or equipment damage may be caused!

Avoid anything falling into the equipment when inverter is running. Or damage may be caused.

Maintenance



Warning

Do not carry out repairs and maintenance of equipment with power on. Otherwise, there is a risk of electric shock!

No specially trained personnel can not make inverter implementation of repairs and maintenance. Otherwise, personal injury or equipment damage may be caused!

Make sure the inverter when the inverter voltage is lower than AC36V implementation of the maintenance and repair, five minutes after power prevail. Otherwise, the residual charge on the capacitor will cause damage!

Make the inverter parameter settings, only with all pluggable plug in and out in the case of power outages!

Precautions

●Motor Insulation Inspection

Motor in use for the first time, placed a long time before re-use and periodic inspection should be done, the motor insulation should be checked, to prevent the motor winding insulation failure and damage to the inverter. To motor insulation check connection separate from the inverter, 500V megger is recommended, should ensure that the measured insulation resistance of not less than 5MΩ.

●Motor Thermal Protection

If the rated capacity of the motor does not match those of the inverter, especially when the rated power of the inverter is higher than the rated power of the motor, be sure to adjust the inverter motor protection parameter values , or thermal relay shall be mounted for motor protection.

●Running with Frequency higher than Power Frequency

This inverter can provide output frequency from 0Hz to 600Hz. If the customer is required to run 50Hz above, consider the mechanical endurance of the device.

●Vibration of Mechanical Device

The inverter may encounter the mechanical resonance point at certain output frequencies, which can be avoided by setting the skip frequency parameters in the inverter.

●Motor Heat and Noise

Since the output voltage of inverter is PWM wave and contains certain harmonics, the temperature rise, noise and vibration of the motor comparing with the power frequency will be increased slightly.

●Use with the voltage different with the rated voltage

If the AE200H series inverter is used outside the allowable working voltage range as specified in this manual, it is easily lead to the inverter devices damage. If needed, use the corresponding boost or lower voltage transformer processing.

●The output side with the pressure-sensitive devices or to improve the power factor capacitor

Since the inverter output is PWM wave, the output side if installed with capacitors to improve the power factor or lightning varistors. Easily lead to the inverter instantaneous overcurrent or even damage the drive, do not use.

●Switching Devices like Contactors Used at the Input and Output terminal

If a contactor is installed between the power supply and the input terminal of the inverter, it is not allowed to use the contactor to control the startup/stop of the inverter. Necessarily need to use the contactor control inverter start and stop of not less than an hour. Frequent charge and discharge will reduce the service life of the capacitor inside the inverter. If switching devices like contactor are installed between the output terminal and the motor, should ensure that the inverter output off operation, otherwise easily lead to the inverter module damage.

●Change Three-phase Input to Two-phase Input

It is not allowed to change the AE200H series three-phase inverter into two-phase.

Otherwise, it may cause fault or damage to the inverter. This operation must be handed under AE200H technical guidance.

●**Lightning Surge Protection**

The series inverter has lightning over current protection device, and has certain self-protection ability against the lightning. In applications where lightning occurs frequently, the user shall install additional protection devices in front of the inverter.

●**Altitude and Derating Use**

Altitude of over 1000m of the region, the heat sink's cooling effect of the inverter may turn poorer due to the thin air. Therefore, it needs to derate the inverter for use. This case please contact our technical advice.

●**Some Special Use**

If the user needs to use the inverter with the methods other than the recommended wiring diagram in this manual, such as DC bus, please consult our company.

●**Cautions of Inverter scrapped**

The electrolytic capacitors on the main circuit and the PCB may explode when they are burnt. Emission of toxic gas may be generated when the plastic parts are burnt. Processed as industrial waste.

●**Adaptable Motor**

- 1) The standard adaptable motor is four-pole squirrel-cage asynchronous induction motor or permanent magnetic synchronous motor. If such motor is not available, be sure to select adaptable motors in according to the rated current of the motor.
- 2) The cooling fan and the rotor shaft of the non-frequency-conversion motor adopt coaxial connection. When the rotating speed is reduced, the heat sink cooling effect will be reduced. Therefore, overheating occasions should be retrofitted with a strong exhaust fan or replace the variable frequency motor.
- 3) Since the inverter has built-in standard parameters of the adaptable motors, it is necessary to perform motor parameter identification or modify the default values so as to comply with the actual values as much as possible, or it may affect the performance and protective properties.
- 4) Since short circuit cable or internal circuit of motor may cause alarm, or even machine explosion, please do insulation and short circuit test before the initial use as well as daily maintenance. Note: be sure to do this test, inverter and tested parts must be all separated!

EMC Guidance

According to the national standard of GB/T12668.3, AE200H comply with the requirements for electromagnetic interference and anti-electromagnetic interference.

AE200H series have passed CE certification.

To obtain good electromagnetic compatibility in general industrial environment, please refer to the following instruction:

Installation of EMC guidance:

- 1) Ground wire of inverter and other electrical products should be well grounded.
- 2) Try not set parallel arrangement for inverter input/output power line and weak electric signal lines, set vertical arrangement if possible.
- 3) The inverter output power line is recommended to use shielded cable, or steel shielded power line, and shielding layer should be reliable grounded. Twisted pair shielded control cable is recommended for wiring of interference device.
- 4) If the distance between the inverter and the motor exceeds 100 meters, output filter or reactor shall be installed.

Input filter installation EMC guidance:

- 1) Note: The filters should strictly be used according to the rated value. As filter belongs to class I appliances, filter metal shell ground should be large area well connected to installation cabinet metal ground, and good conductive continuity is required. Otherwise there will be risk of electric shock and serious impact on the EMC effect.
- 2) EMC test proves, filter and PE end must be connected to the same public ground, otherwise it will seriously affect the EMC effect.
- 3) Filter should be installed as close as possible to the inverter power supply input.

Contents

Section I. Product Information.....	1
1-1 Nameplate specification	1
1-2 Model specification	1
1-3 Product series	2
1-4 Product shape	2
1-5 Standard specification	3
Section II. Installation & Wiring	12
2-1 Use of the environment	12
2-2 Handling and installation.....	12
2-3 Wiring	14
2-4 Main circuit terminals function	16
2-5 Control circuit terminals.....	16
Section III. Fittings	24
3-1 Connection with peripheral devices	24
3-2 Braking unit & Braking resistance	26
Section IV. Keyboard Operation.....	32
4-1 Display Interface	32
4-2 Examples for parameter setting	34
Section V. Parameter Function Table	40
5-1 Parameter	错误! 未定义书签。
Section VI. Fault Diagnosis & Solutions	138
6-1 Fault alarm and solutions	76
6-2 Common fault and solutions	76
Section VII. Inspection & Maintenance.....	147

7-1	Inspection and Maintenance.....	147
7-2	Regular replacement of the device	148
7-3	Storage	148
7-4	Measuring and Judgment	148
7-5	Safety Precaution	148

Appendix I DN5RS485 Card & RS485 Communication Protocol..... 149

I-1	DN5RS485 card.....	149
I-2	Mechanical installation and control terminal function description.....	149
I-3	Communication protocol	150
I-4	Cyclical Redundancy Check:	153

Appendix II Multi-function Card DN5PC1 158

II-1	Outline.....	158
II-2	Mechanical installation and control terminal function description.....	158
III-1	Outline.....	160
III-2	Mechanical installation and control terminal function description.....	160
IV-1	Outline	163
IV-2	Mechanical installation and control terminal function description.....	163

Appendix III Product Feedback..... - 167 -

Section I. Product Information

AE200H frequency inverters have been tested and inspected before leaving the manufacturer. Before unpacking the product, please check product packaging for shipping damage caused by careless transportation and whether the specifications and type of the product complies with the order. If any questions, please contact the supplier of AE200H products, or directly contact the company.

- ※ Inspect that the contents are complete (one unit of AE200H frequency inverter, one operation manual).
- ※ Check the nameplate on the side of the frequency inverter to ensure that the product you have received is right the one you ordered.

1-1 Nameplate specification

MODEL: AEXX-4-3PH11G/15P
INPUT: 3PH AC 380V 50Hz/60Hz
OUTPUT: 3PH AC 0-380V 25A/32A
POWER: 11KW/15KW

1-2 Model specification

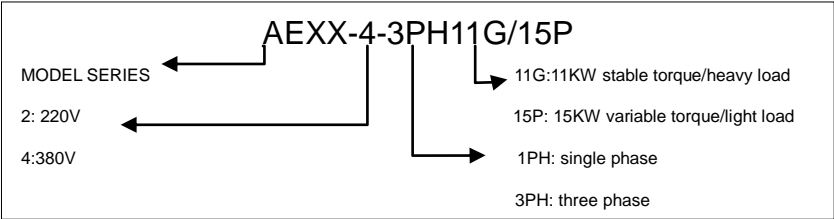

<p>GP unification Model description</p>	<p>Users check factory models through P0.00. P type is one lower power than G type.</p> <p>E.g: If you need 11kw P type, 7.5kw G type could be selected as a replacement. Its input current is the rated input current (20.5A) of 7.5kw G type, but its rated power is that of 11kw G type, and output current is the rated output current(25A) of 11kw G type.</p> <p>Though inverter hardware of GP unification is different, there are some optimizations of software parameters for different load types .</p> <p>P type model is only suitable for pump, fan etc light load models, can not work at the rated current or more than the rated frequency for a long time.</p>
---	--

1-3 Product series

POWER SUPPLY VOLTAGE AC	Product series	Power of Inverter kW	Rated output A
220V SINGLE PHASE INPUT AND 3PHASES OUTPUT	AE200-2S0.4G	0.5	2.4
	AE200-2S0.75G	0.75	4.5
	AE200-2S1.5G	1.5	7
	AE200-2S2.2G	2.2	10
	AE200-2S3.7G	3.7	16
THREE-PHASE 380V	AE200-4T0.75G	0.75	2.5
	AE200-4T1.5G	1.5	3.7
	AE200-4T2.2G	2.2	5
	AE200-4T4.0G	4.0	9
	AE200-4T5.5G	5.5	13
	AE200-4T7.5G	7.5	17
	AE200-4T11G	11.0	25
	AE200-4T15G	15.0	32
	AE200-4T18.5G	18.5	37
	AE200-4T22G	22	45
	AE200-4T30G	30	60
	AE200-4T37G	37	75
	AE200-4T45G	45	90
	AE200-4T55G	55	110
AE200-4T75G	75	152	

1-4 Product shape

Section I. Product Information

	Torque control precision	±5%(FVC)
	Over load capability	rated current 150% -1 minute, rated current 180% -10 seconds;
	Torque boost	Auto torque boost function: Manual torque boost 0.1%~30.0%
	V/F curve	Linear V/F, Multi-point V/F and Square V/F curve
	V/F separation	In 2 ways: separation ,semi separation
	Acc. /dec curve	Straight line or S curve acceleration and deceleration mode. Four kinds of acceleration and deceleration time. Acceleration and deceleration time range between 0.0s to 3000.0min
	DC brake	DC brake frequency: 0.00Hz to maximum frequency, brake time: 0.0s to 36.0s, and brake current value: 0.0% to 100.0%.
	Jog control	Jog frequency range: 0.00Hz~50.00Hz. Jog acceleration/deceleration time 0.0s~6500.0s.
	Simple PLC and MS speed running	It can realize at maximum of 16 segments speed running via the built-in PLC or control terminal.
	Built-in PID	It is easy to realize process-controlled close loop control system
	Auto voltage regulation (AVR)	It can keep constant output voltage automatically in case of change of network voltage.
	Over-voltage/current stall control	It can limit the running voltage/current automatically and prevent frequent over-voltage/current tripping during the running process
	Quick current limit	Minimize the over-current fault, protect normal operation of the inverter
	Torque limit & control	"Excavators" characteristics, automatically limit torque during operation , prevent frequent over-current trip; Closed loop vector mode can realize the torque control.
Personalized	Instantaneous stop non-stop	When instantaneous power off, voltage reduction is compensated through load feedback energy, which could make inverter keep running in a short period of time.
	Rapid current limit	To avoid inverter frequent over-current fault.
	Virtual IO	5 groups of virtual DI, DO to realize simple logic control
	Timing control	Timing control function: set time range 0Min~6500.0Min
	Multiple motor switch	4 groups of motor parameter, which can realize 4-motor switch control
	Multi-threaded bus support	Support 4 kinds of field bus: RS485, Profibus-DP, CANlink, CANopen
	Motor overheat protection	Select optional DN5PC1 analog input AI3x can accept the motor temperature sensor input
	Multi-encoder support	Support difference, open collector, UVW, rotary transformer, sine cosine encoder etc.
Running	Excellent backend software	Support inverter parameter operation and virtual oscilloscope function. Inverter internal state graphic monitor can be realized through virtual oscilloscope.
	Running command channel	Three types of channels: operation panel reference, control terminal reference and serial communication port reference. These channels can be switched in various modes.
	Frequency source	There are totally eleven types of frequency sources, such as digital reference, analog voltage reference, analog current reference, pulse reference, MS speed, PID and serial port reference.
	Auxiliary frequency source	11 kinds of auxiliary frequency source which can flexible achieve auxiliary frequency tuning, frequency synthesis
	Input terminal	Standard: There are 6 digital input terminals, S5 can be used as 100kHz high-

Section I. Product Information

		<p>speed input pulse.</p> <p>3 analog input terminals which can be used as 0-10V voltage input or 0~20mA current input.</p> <p>Extended function:</p> <p>4 digital input terminals, support-10~10V voltage input & PT100\ PT1000.</p>
	Output terminal	<p>Standard:</p> <p>2 digital output terminals, FM is high-speed pulse output terminal (can be chosen as open circuit collector type), support 0~10kHz square wave signal;</p> <p>1 relay output terminal;</p> <p>2 analog output terminals, support 0~20mA output current or 0~10V output voltage;</p> <p>1 digital output terminal;</p> <p>1 relay output terminal ;</p> <p>1 analog output terminal, support 0~20mA output current or 0~10V output voltage.</p>
Keyboard operation	LED display	Realize parameter setting, status monitoring function
	Keyboard potentiometer	Equipped with keyboard potentiometer or coding potentiometer
	Key lock&function selection	Realize button locking, define operation range for part of buttons to prevent operation fault.
	Protection function	It can implement power-on motor short-circuit detection, input / output phase loss protection, over current protection, over voltage protection, under voltage protection, overheating protection and overload protection
	Optional parts	RS485 communication card, digital setting, Analog setting, multi-speed, PID setting
Environment	Using place	Indoor, and be free from direct sunlight, dust, corrosive gas, combustible gas, oil smoke, vapor, drip or salt.
	Altitude	Below 1000m
	Ambient temperature	-10 ℃ to +50 ℃ (Derating use when under ambient temperature of 40 ℃ to 50 ℃)
	Humidity	Less than 95%RH, without condensing
	Vibration	Less than 5.9 m/s ² (0.6g)
	Storage temperature	-10℃~+50℃

Table: 1-5.1

Section II. Installation & Wiring

2-1 Use of the environment

- 1) Ambient temperature-10°C~50°C.
- 2) Avoid electromagnetic interference and keep the unit away from the source of interference.
- 3) Prevent dropping water, steam, dust powder, cotton fiber or fine metal powder from invasion.
- 4) Prevent oil, salt and corrosive gas from entering it.
- 5) Avoid vibration. Vibration should be less than 0.6G. Keep away from punching machine etc.
- 6) Avoid high temperature, moisture or being wetted due to raining, with the humidity below 95%RH (non-condensing).
- 7) Prohibit the use in the dangerous environment where inflammable or combustible or explosive gas, liquid or solid exists.

2-2 Handling and installation

- ※ When transporting inverter, right lifting tools are required to prevent inverter from damaging.
- ※ The number of stacked box of the inverter are not permitted higher than the limit.
- ※ Please don't run the inverter if there is damage or lacking of components.
- ※ Do not place heavy objects on the frequency inverter.
- ※ Please prevent screw, cable pieces or other conductive objects or oil etc inflammable objects invading the frequency inverter.
- ※ Do not make it fall or have a strong impact.
- ※ Confirm if the installation location and object could withstand the weight of the inverter. The frequency inverter must be installed by wall hooking、 indoor room with adequate ventilation, with enough space left between it and the adjacent objects or retaining board (walls) around, as shown in the picture below:

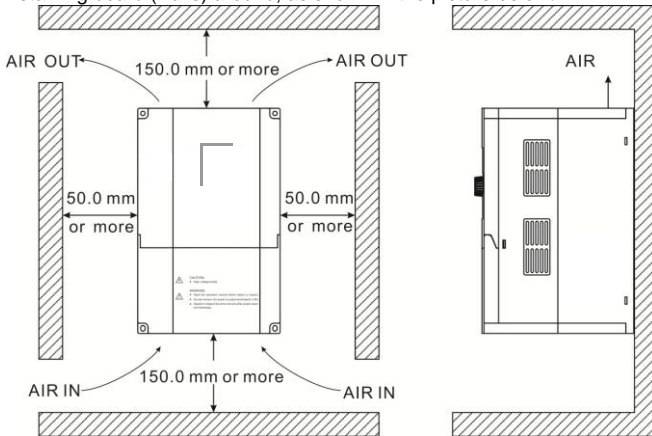

Fig. 2-2.1

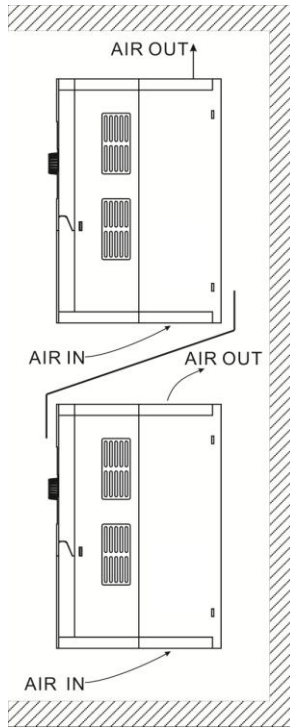

Fig. 2-2.2

Heat dissipation problems should be concerned when doing mechanical installation, please mind rules belows:

- 1) Mounting space is shown in 2-2.1, which could ensure the heat sinking space of the inverter. However, the heat sinking of other devices in the cabinet shall also be considered.
- 2) Install the inverter vertically so that the heat may be expelled from the top. However, the equipment cannot be installed upside down. If there are multiple inverters in the cabinet, parallel installation is better. In the applications where up-down installation is required, please install the thermal insulating guide plate referring to the Fig. 2-2.2 for standalone
- 3) Installing support must be flame retardant materials.
- 4) It is suggested that cooling cabinet be put outside at places where powder dust exists. Space inside the sealed cabinet shall be large as much as possible.

2-3 Wiring

The wiring of frequency inverter includes two parts: main circuit and control circuit. Users must ensure correct connections according to the following connection diagram.

2-3-1 AE200H diagram

1) Below 30kW wiring diagram

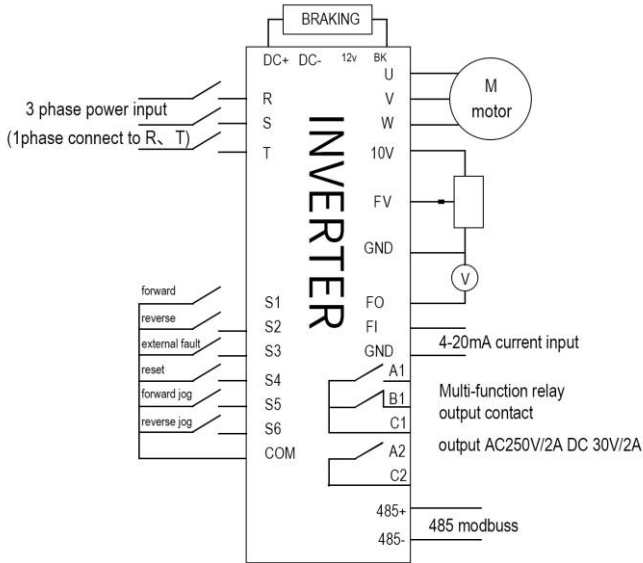

Fig. 2-3.1

2)Above30KW wiring diagram

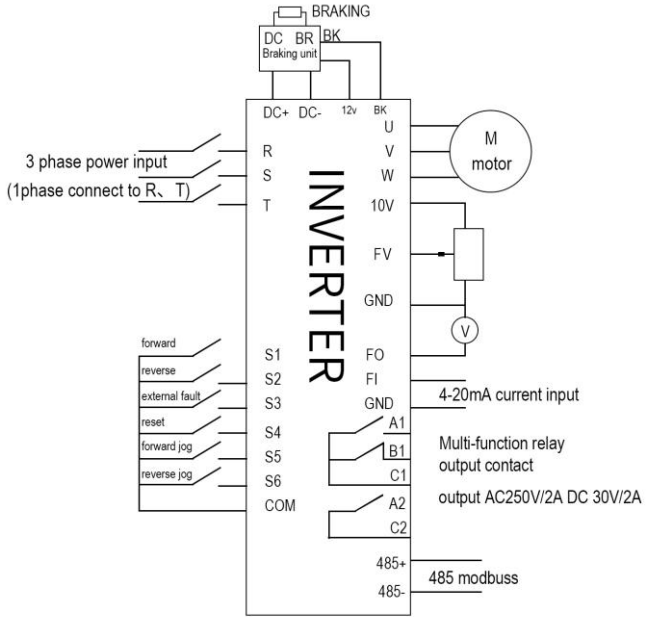



Fig. 2-3.2

2-4 Main circuit terminals function

Terminal	Description	Functions
R	Power input for the frequency inverter	Connect three-phase power supply, single phase input connect to R, T
S		
T		
 /E	Earthing terminal	Earthing
DC+, PB	Connection point for braking resistor	Connect to braking resistor (under 18.5KW)
U	Output terminal	Connect to three-phase motor
V		
W		
DC+, DC-	DC bus output terminal	Connect to braking unit(18.5KW—55KW)
DC+, PI	DC reactance terminals	Connect to DC reactance(remove short block)(above 75KW)

Note:

- 1) Use the terminals with insulating tubes to connect motor and power supply.
- 2) Do not connect the power supply to U, V, W, otherwise may cause serious damage
- 3) While drilling avoid powder splashing into inverter and bits and pieces of cables must be cleaned out otherwise may cause serious damage.
- 4) To make sure the voltage is reduced within 2%, use the appropriate type of wire for wiring. If the distance between inverter and motor is too long, the motor torque will be reduced due to the voltage drop of the main circuit cable, especially when the inverter is at low frequency output state.
- 5) When the distance between inverter and motor is over 50 meters, parasitic capacitance effect of long cable to ground may easily happen, thus causing a large leaking current and triggering over current protection alarm. Besides, In order to avoid motor insulation damage, the output end needs to add output reactor for compensation.
- 6) It is recommended to connect the brake resistor option between DC+ and BR-.
- 7) Electromagnetic interference: The input and output circuits contain harmonic wave a radio noise filter can be installed at the input when needed.
- 8) Do not install power capacitor at the output terminals of inverter which may cause serious damage
- 9) If you need to change wiring while running, please wait at least 10 minutes after power off and use a multimeter to check the voltage to make sure it is safe. There is still a high voltage hazard on the capacitor for some time after power off.
- 10) ※the inverter and motor must be earthing.
 - ※Use a separate earthing terminal for earthing.
 - ※It is recommended to ground with a thick cable and make sure to near the inverter, the shorter the better.
 - ※One of the four core cables is used for motor grounding, with the same specification as the input cable.

2-5 Control circuit terminals

2-5-1 Control circuit terminals

FA series Control circuit terminals: the Analog terminal and Earthing terminal is the same terminal: COM; which can be connected to 10V Output or 12V Output as power supply.

A1	B1	C1	12V	10V	FV	FI	FO	COM	S1	S2	S3	S4	S5	S6
----	----	----	-----	-----	----	----	----	-----	----	----	----	----	----	----

AE series Control circuit terminals:

485+	485-	BK	12V	GND	FO	FI	GND	FV	10V	A2	C2	
	24V	COM	S1	S2	S3	S4	S5	S6	COM	A1	B1	C1

2-5-2 Control circuit terminals description

Terminals function description:

Type	Terminal sign	Terminal Name	Function Description
Power supply	+12V-GND	External terminal of 12V power supply	Provide +12V power supply for external units, with maximum output current of 50mA. It is generally used as the operating power supply for the external potentiometer. The potentiometer resistance range is 1kΩ to 5kΩ.
	+24V-COM	External terminal of 24V power supply	Provide +24V power supply for external units. It is generally used as the operating power supply for digital input/output terminal and the external sensor. Maximum output current: 50mA
	10V	Power supply for frequency setting	Power supply for external potentiometer(4.7K-10K)
Analog input	FV-GND	Analog input terminal 1	1. Input voltage range: DC 0V to 10V, connect to potentiometer or 0V to 10V signal. 2. use for frequency setting; given PID or feedback PID
	A12-GND	Analog input terminal 2	1. Input range: DC0mA~20mA 2. use for frequency setting; given PID or feedback PID
Analog output	FO-GND	Analog output	Output voltage range: 0V to 10V Output current range: 0mA to 20mA. can be connected to DC 10V voltmeter,can display frequency,output voltage, Output current,can be switched by switch
+485-	RS485	RS485 communication	A terminal for serial communication with the outside
Signal Output	12V-BK	Brake signal output	connect external brake units
Relay	A1,B1,C1	Relay contact J1,J2	A1,C1 are normally open contacts; B1,C1 are

Section II. Installation & Wiring

output	A2,C2	output	normally close contacts; the factory default setting of J1 signal output is forward; J1 signal output is Fault status.
Multi function input	S1	Multi function input terminal	the factory default setting is forward
	S2	Multi function input terminal	the factory default setting is reversal
	S3	Multi function input terminal	the factory default setting is external fault input
	S4	Multi function input terminal	the factory default setting is fault reset
	S5	Multi function input terminal	the factory default setting is forward jog
	S6	Multi function input terminal	the factory default setting is reversal jog
	COM	Multi function input common terminal	common terminal for S1-S6, conjunction with S1-S6

Note:

- 1) COM is common terminal for S1-S6, GND is common terminal for A11,F1,FO,BK; Please do not earthing.
- 2) Use twisted-pair cable to connect the control circuit terminals and make sure to separate wiring with main circuit and strong current circuit
- 3) Use 0.75 mm² cable to connect Control circuit
- 4) Input strong current may cause damage to control circuit.

Section III. Fittings

3-1 Connection with peripheral devices

3-1-1 Wiring diagram of peripheral devices

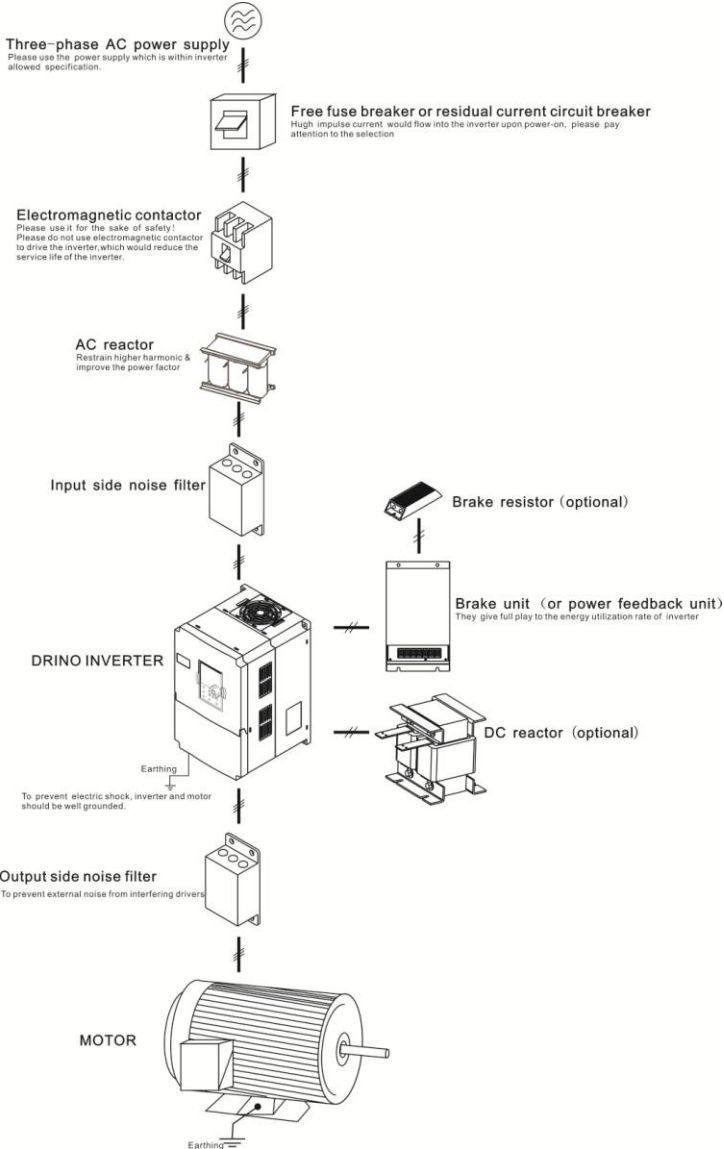

3-1-2 Peripheral Electric Parts of AE200H

Part Name	Installation Location	Function Description
Circuit breaker	The front-end of the input circuit	Disconnect the power supply in case of downstream equipment is over current
Contactor	Between the circuit breaker and the inverter input side	Power-on and power-off of the inverter. Frequent power-on/power-off operation (at least once per minute) on the inverter should be avoided
AC input reactor	Input side of the inverter	Improve the power factor of the input side: 1.Eliminate the high order harmonics of the input side effectively, and prevent other equipment from damaging due to voltage waveform deformation. 2.Eliminate the unbalanced input current due to the unbalanced power phases.
EMC input filter	Input side of the inverter	1.Reduce the external conduction and radiation interference of the inverter; 2.Reduce the conduction interference flowing from the power end to the inverter, thus improving the anti-interference capacity of the inverter. 3.The common size of 3-phase EMI noise filter is shown as following: confirm the power supply is 3-phase three lines or 3-phase four lines or single phase. Grounding wire is as short as possible, try to place the filter near the converter. Please choose EMI filter when the inverter is used in residential area, commercial area, science area as well as situations where higher demand to prevent radio interference is needed or meeting CE、UL、CSA standard but existing equipment that anti-interference ability is not sufficient. If needing the filter, please connect with the company.
DC reactor	AE200H series can adopt external DC reactor according to the need.	Improve the power factor of the input side: 1.Improve the overall efficiency and thermal stability 2.Effectively reduce the influence of high order harmonics at the input side on the inverter and reduce the external conduction and radiation interference.
AC output reactor	Between the inverter output side and the motor, close to the inverter	The inverter output side generally has higher harmonic.When the motor is far from the inverter, since there are many capacitors in the circuit, certain harmonics will cause resonance in the circuit and bring in the following results: 1.Degrade the motor insulation performance and damage the motor for the long run 2.Generate large leakage current and cause frequent

		inverter protection action 3.In general, if the distance between the inverter and the motor exceeds 100 meters, output AC reactor should be installed
Output EMI filter	Between the inverter output side and the motor, close to the inverter	The fittings can restrain the disturbance noise and lead line leak current produced in the output side.

Table: 3-1.1

3-2 Braking unit & Braking resistance

When customers choose the type with braking,there will be braking unit inside the inverter, maximum braking torque is 50%.Please refer to the table below and choose the matched braking resistance separately.

Specification	Power of Inverter (kW)	Brake resistance(Ω)	Power of brake resistance(W)
220V	0.4	200	80
	0.75	200	80
	1.5	100	250
	2.2	75	250
	4.0	40	400
380V	0.75	750	80
	1.5	400	250
	2.2	250	250
	4.0	150	400
	5.5	100	500
	7.5	75	800
	11	50	1000
	15	40	1500
	18.5	30	4000
	22	30	4000
	30	20	6000
	37	16	9000
	45	13.6	9000
	55	10	12000
75	6.8	18000	

	90	6.8	18000
	110	6	18000

Table: 3-2.1

If you need accessories in the table, please declare in order.

For larger built-in braking torque, please use the AE200H braking unit.

Other large power models do not contain a built-in braking. If large power model need to be equipped with braking function, please choose AE200H braking unit.

External DC reactor installation:

For AE200H series inverter, external DC reactor can be ordered according to your needs. When installation, you should tear down copper platoon between DC+1 and DC+2 of inverter main circuit. And then add reactor between DC+1 and DC+2, wiring between reactor terminals and inverter terminals DC+1 and DC+2 have no polarity. After installation of dc reactor, short circuit copper platoon between DC+1 and DC+2 is no more used.

3-2-1 Specifications of circuit breaker, cable and contactors

POWER SUPPLY VOLTAGE AC	Specification	Circuit Breaker (MCCB) (A)	Input/Output cable (copper core cable)mm ²	Rated working current of contactor A (Voltage 380V or 220V)
Single Phase 220V	AE200-2S0.4G	10A	1.5	10
	AE200-2S0.75G	16A	2.5	10
	AE200-2S1.5G	20A	2.5	16
	AE200-2S2.2G	32A	4	20
	AE200-2S4.0G	40A	6	25
	AE200-2S5.5G	63A	6	32
	AE200-2S7.5G	100A	10	63
	AE200-2S11G	125A	10	95
	AE200-2S15G	160A	25	120
	AE200-2S18.5G	160A	25	120

Section III. Fittings

THREE-PHASE 380V	AE200-4T0.75G	10A	1.5	10
	AE200-4T1.5G	16A	1.5	10
	AE200-4T2.2G	16A	2.5	10
	AE200-4T4.0G	25A	2.5	16
	AE200-4T5.5G	25A	4	16
	AE200-4T7.5G	40A	4	25
	AE200-4T11G	63A	6	32
	AE200-4T15G	63A	6	50
	AE200-4T18.5G	100A	10	63
	AE200-4T22G	100A	10	80
	AE200-4T30G	125A	16	95
	AE200-4T37G	160A	25	120
	AE200-4T45G	200A	35	135
	AE200-4T55G	250A	35	170
	AE200-4T75G	315A	70	230
	AE200-4T93G	400A	70	280
	AE200-4T110G	400A	95	315
	AE200-4T132G	400A	95	380
	AE200-4T160G	630A	150	450
	AE200-4T187G	630A	185	500
	AE200-4T200G	630A	240	580
	AE200-4T220G	800A	150x2	630
	AE200-4T250G	800A	150x2	700
	AE200-4T280G	1000A	185x2	780
	AE200-4T315G	1200A	240x2	900
	AE200-4T355G	1280A	240x2	960
AE200-4T400G	1380A	185x3	1035	
AE200-4T500G	1720A	185x3	1290	

Table: 3-2.2

Section IV. Keyboard Operation

4-1 Display Interface

Modification of function parameter, monitoring of inverter operation, control of inverter operation (start and stop) can be performed through the operation panel. Its shape and function area are shown as below:



Fig. 4-1.1

4-1-1 Function description of operation panel

Keyboard Parameter	Description
FWD	Forward Running Light *ON: forward running
REV	Reverse Running Light *ON: reverse running
RUN	Running indicator *ON: running state

Section IV. Keyboard Operation

STOP	Stop indicator *ON: stop state
LINK	Command source indicator keyboard operation, terminal operation and remote operation (communication control) indicator *ON: terminal operation control state *OFF: keyboard operation control state *Flashing: remote operation control state
JOG	Multi-function indicator *ON: Multi-function mode
Digital display	Digital display area *5-bit LED display,monitor set frequency,output frequency,various monitoring data,alarm code etc.
PROG	Programming key *Primary menu enter or exit
>>/REV	Shift key *On the stop display interface or running display interface, it can be used to circularly select the display parameters. When modifying the parameters, it can be used to select the bits of parameter for modification
DATA	Confirmation key *Gradually step into the menu screen, set parameters confirmation
^	Increase key *Increase of the data or function code
∨	Decrease key *Decrease of the data or function code
JOG	Forward Reverse Running selection key / JOG key *It is used as Forward Reverse Running function switching selection according to P.022=1.
RUN	Running key * It is used to start the running of the inverter under keyboard control mode
STOP/RESET	Stop/reset * In running status, it can stop the running by pressing this key. In alarm status, it can reset operation with this key. The characteristics of this key are limited by function code P.023.

Table 4-1.2

4-2 Example for parameter setting

4-2-1 Description of function code viewing and modification method

The operation panel of AE200H inverter adopts three-level menu structure to perform parameter setting. The three-level menu includes: function parameter group (level 1 menu) → function code (level 2 menu) → setting value of function code (level 3 menu). The operation process is as shown in Figure below.

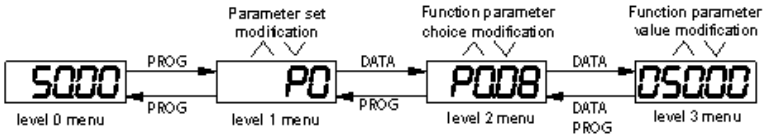

Table 4-2.1

Caution: When operating on level 3 menu, press PROG key or DATA key to return to level 2 menu. The difference between DATA and PROG keys is that pressing DATA KEY will save the setup parameter and return to level 2 menu and then automatically shift to the next function code, while pressing PROG key will directly return to level 2 menu without saving the parameter, and it will return to the current function code.

Take the modification of function code P3.02 (ranging from 10.00Hz to 15.00Hz) as an example. (The boldface bit indicates the flashing bit).

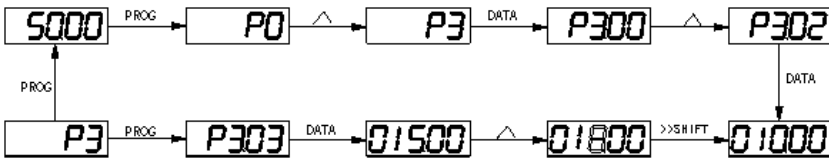

Table 4-2.2

In level 3 menu, if the parameter has no flashing bit, it indicates that the function code cannot be modified. The possible reasons include:

- 1) The function code is an unchangeable parameter, such as actual detection parameter, running record parameter, etc.
- 2) The function code cannot be modified in running status but can be modified after the unit is stopped.

Section V. Parameter Function Table

Caution:

The symbols in the function table are explained as follows:

“★”: indicates that the parameter setup value cannot be modified when the inverter is in the running status.

“●”: indicates that the parameter value is the actual detection record and cannot be modified.

“☆”: indicates that the parameter setup value can be modified when the inverter is in stop status and running status.

“▲”: indicates that the parameter is “Factory default parameter” and can be set only by the manufacturer, and the user is forbidden to perform any operation.

“-”: indicates that the parameter factory value is relevant to power or model, for specifications please refer to corresponding parameter description.

“Change limit” indicates if the parameter is adjustable during operation.

5-1 Parameter

Code	Description/Display	Setting Range		Factory Setting	Change Limit
P0.00	Command source selection	Operation panel command channel (LED off)	0	0	☆
		Terminal command channel(LED on)	1		
		Serial port communication command channel (LED flashing)	2		
		Automatic channel recognition (Operation panel or Terminal command)	3		
<p>Inverter control commands include: run, stop, forward rotation (FWD), reverse rotation (REV), forward jog (FJOG), reverse jog (RJOG), etc.</p> <p>0: Operation panel command channel (“LOCAL/REMOT” LED off); Perform running command control with RUN, MF.K and STOP/RESET keys on the operation panel.</p> <p>1: Terminal command channel (“LOCAL/REMOT” LED on); Perform running command control with multifunctional input terminals such as FWD, REV, FJOG, RJOG, and so on.</p> <p>2: Serial port communication command channel (“LOCAL/REMOT” LED flashing). The running command is given by the host computer via the communication mode. When the item is chosen, it must be equipped with communication card(Modbus RTU、Profibus DP card、CANlink card、users programmable control card or CANopen card and so on).</p> <p>For the communication protocol, please refer to “PD group communication parameters” and supplementary explanation of corresponding communication card for details. Supplementary explanation for communication card is allotted with communication card. This manual contains a brief description of communication card.</p>					
P0.01	Motor 1 control mode	Speed sensorless vector control(SVC)	0	0	★
		V/F control	1		
0: Speed sensorless vector control					

<p>It refers to the open-loop vector control that is generally applied to high performance control field. One inverter can only drive one motor. E.g: machine tool, centrifugal machine, fiber drawing machine, injection molding machine' load etc.</p> <p>1: V/F control</p> <p>V/F control mode is suitable for fields that load demand is not high or one inverter can drive multiple motos. E.g: draught fan, pump' load etc.</p> <p>Tips: Motor parameters must be indentified before choosing vector control mode. Only accurate motor parameters can play the advantage of vector control mode. Users can get better performance by adjusting speed regulator group P2 parameters(motor 2,motor 3,motor 4 respectively for group A2,A3,A4)</p> <p>FVC is generally used for permanent magnet synchronous motor, while part of the small power applications can select V/F control mode. AE200H series support specific models of permanent magnet synchronous motor sensorless vector control mode. Please refer to AE200H users manual and AE200HS dedicated users manual for using method.</p>					
P0.02	Digital setup frequency memory selection upon stop	Memory	0	0	☆
		Without memory	1		
		Without operation	2		
<p>This function is only valid when frequency source is digital setup.</p> <p>0: Memory</p> <p>Digital setup frequency is the retention that reserved at last stop time. Keyboard “^”、“v” or terminal UP、DOWN to make the correction valid.</p> <p>1: Without memory</p> <p>Upon power fault or stop of the inverter, set the frequency value back to the setup value of “Preset Frequency” (P0.08). Frequency modification which set through keyboard “^”、“v” or terminal UP、DOWN is cleared.</p> <p>2: Without operation</p> <p>No operation, tuning is forbidden.</p>					
P0.03	Main frequency source X selection	Digital setup	0	7	★
		FV	1		
		FI	2		
		Potentiometer	7		
		FV+ FI	3		
		Retain	4		
		PID setup	5		
Communicaton setup	6				
<p>This parameter is used to select the main reference frequency input channel. Totally 10 main reference frequency channels:</p> <p>0: Digital setup(power off without memory)</p> <p>Initial value of set frequency equals to P0.08 “preset frequency”. User can change inverter set frequency value through keyboard ^ key and v key (or multi-function input terminal UP,DOWN).</p> <p>Inverter power on after powered off, frequency set value restored to P0.08 “Preset frequency”.</p> <p>1: FV</p> <p>2: FI</p> <p>3: FV+ FI</p> <p>4: Retain</p> <p>5: PID setup</p>					

Section V. Parameter Function Table

Running frequency is the output of PID control process. Generally used for field process closed-loop control.

When PID is chosen, user should set relevant parameters of PA group "PID function".

6: Communicaton setup

Communication setup refers to main frequency source that setting through communication method of position machine.

AE200H series support 4 kinds of communication mode: Modbus、Profibus.DP、CANopen、CANlink. 4 kinds of communication can not be used at the same time.

Communication card should be installed during the use of communication.4 kinds of communication card are optional.User can select to buy according to the needs, and set parameter P0.28 correctly.

7: Potentiometer

Frequency is determined by analog input terminal. AE200H series control board offers 2 analog input terminal(FV, FI).

FV, FI can be chosen as 0V~10V voltage input as well as 4mA~20mA current input by the jumper J1, J2 on control board.

FV, FI input voltage value has a corresponding relationship with target frequency, users can choose them at will. AE200H offers 5 groups of corresponding relation curve, which 3 of them are linear relationship(2-point correspondence), 2 of them are 4-point correspondence(any curve among them). User can set through P4 group or A6 function code.

P.004	Maximum frequency	10.00Hz~600.00Hz	50.00Hz	★
-------	-------------------	------------------	---------	---

When analog input, pulse input(S5), MS command etc are used as frequency source, their respective 100% are relatively calibrated through P.004.

AE200H maximum frequency could reach 600Hz. Users can set decimal digits of frequency command through P0.22 to balance the idex of frequency command resolution and frequency input range.

P.005	Frequency upper limit	Frequency lower limit(P.006) to maximum frequency(P.004)	50.00Hz	☆
-------	-----------------------	--	---------	---

P.006	Frequency lower limit	0.00Hz to frequency upper limit P.005	0.00Hz	☆
-------	-----------------------	---------------------------------------	--------	---

When the running frequency of the inverter is lower than the frequency lower limit, it can select to run at frequency lower limit or stop the inverter.

P0.07	Acceleration time 1	0.1s~3600.00s	-	☆
-------	---------------------	---------------	---	---

P0.08	Deceleration time 1	0.1s~3600.00s	-	☆
-------	---------------------	---------------	---	---

The acceleration time means the time t1 needed for the inverter to accelerate from 0Hz to the reference frequency.

The deceleration time means the time t2 needed for the inverter to decelerate from the reference frequency to 0Hz.

The description of acceleration and deceleration time are as shown in Fig.5.1:

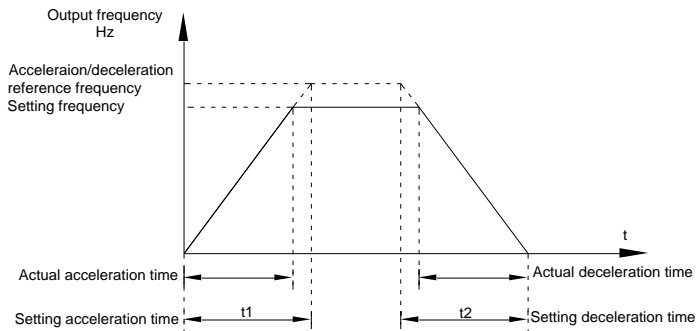

Fig.5-1 Acceleration/deceleration time schematic diagram

AE200H totally offers 4 groups of speed-up/speed-down time for selection, you can shift through digital input terminal DI, 4 groups of them are shown as follows:

GROUP 1: P.007、P.008;

GROUP 2: P.176、P.177;

GROUP 3: P.178、P.179;

GROUP 4: P.180、P.181.

P0.09	digital setting frequency	0.00Hz to P.004 maximum frequency (It is only valid when frequency source is set to "digital setting")	50.00Hz	☆
When set the frequency source to "digital setting" or "terminal UP/DOWN", the parameter value is the initial value of the inverter frequency digital setting.				
P0.10	Running direction	Forward direction	0	☆
		Reverse direction	1	
		Consistent direction	2	
Modification of this parameter can change the rotary direction of the motor without changing any other parameters, which is equivalent to the role of switching the rotary direction through adjusting any two lines of the motor (U, V and W). When needing to change the rotary direction of the motor, users can modify this parameter rather than adjust the wiring of the motor. Caution: When the function code is restored to the factory default value, this parameter value is restored to 2, which should be used prudently in the applications where the motor rotary direction is not allowed to change.				
P0.11	Carrier frequency	1.0kHz~15.0kHz	-	☆
This function is used to adjust the carrier frequency of the inverter. By adjusting the carrier frequency, the motor noise can be reduced, the resonance of the mechanical system can be avoided, so that the leakage current to the ground and the interference of the inverter can be reduced. When the carrier wave frequency is low, the output current higher harmonic component will be increased, the motor loss will be increased, and the motor temperature rise will also be increased. When the carrier wave frequency is high, the motor loss is reduced, and the motor temperature rise is reduced, but the inverter loss and inverter temperature rise will be increased, and thus the interference will be increased. The adjustment of carrier frequency will influence the following items on the performance:				
		Carrier frequency	low → high	
		Motor noise	big → small	

Section V. Parameter Function Table

Output current waveform	poor → well
Motor temperature rise	high → low
Inverter temperature rise	low → high
Leakage current	small → large
Radiation interference	small → big

Different power of inverter is set with different carrier frequency by the factory. Though user could modify it , attention should be paid: if carrier frequency is set higher than the factory set value, it will lead to inverter radiator temperature rise increasing. User should take inverter derating use, or there will be danger of overheating alarm.

P.012	Parameter initialization	No function	0	0	★
		Restore to factory default value, motor parameter not included	1		
		Clear memory	2		
		Retain	3		
		Restore to factory default value, included motor parameter	4		
<p>0: No function.</p> <p>1: Restore to factory default value, motor parameter not included The inverter restores all the parameters excluding the following parameters of the factory default values</p> <p>2: Clear memory The inverter clears the fault records to zero.</p> <p>3: Retain</p> <p>4: Restore to factory default value, included motor parameter It is used to restore to factory default value, included motor parameter which is set through P.012=4.</p>					
P.013	Tuning selection	Without operation	0	0	★
		Asynchronous static tuning	1		
		Asynchronous complete tuning	2		
<p>Caution: Correct motor ratings must be set before tuning</p> <p>0: No operation, tuning is forbidden.</p> <p>1: Asynchronous motor static tuning Before Asynchronous motor static tuning, the asynchronous motor and the load should be torn off. And Motor and the load should be disconnected and static state and the acceleration and deceleration time(P.007, P.008) shall be set appropriately according to the inertia of the motor. Otherwise, overcurrent fault may occur during asynchronous motor static tuning. Correct motor type and motor nameplate parameters P.029~P.033 must be set before static tuning. Set P.0013=1, press DATA , the screen flashing display "-TUN-" then press "RUN" to start motor static tuning. The screen display in sequence "TUN0"...."TUN4".When all procss finished, it display "-END-" and back to shutdown status interface. When the screen flashing display "-TUN-" you can press "PROG" or "STOP" to sign out. Warning: The start and stop of Tuning selection process can only be operated through the keyboard. When Tuning selection process is finished , P.013 are automatically restored to 0.</p> <p>2: Asynchronous complete tuning Motor and the load is not necessary be disconnected. Correct motor type and motor nameplate parameters P.029~P.033 must be set before complete tuning. After tuning the stator resistance, rotor resistance and leakage inductance of the motor will be detected.</p>					

P0.14	AVR function selection	Invalid	0	2	☆
		Valid	1		
		Invalid when Deceleration	2		
		Auto	3		
<p>AVR is Automatic output Voltage Regulation function: Invalid: The output voltage varies with the input voltage (DC bus voltage) Valid: The output voltage will not vary with the input voltage (DC bus voltage), the output voltage will remain constant within the output capacity range. Caution: When the motor is decelerating and stopping, turn off AVR function(P0.14=2), and it will decelerate and stop in a shorter time without overpressure.</p>					
P0.15	Start mode	Direct startup	0	0	☆
		DC braking before startup	1		
		Revolving speed tracking startup	2		
<p>0: Direct startup: When the DC brake time is zero, it starts at the startup frequency. When the DC brake time is non-zero value, it can perform DC brake before start. It is suitable for the applications where small inertia may cause reverse rotation at the time of startup.</p> <p>1: DC braking before startup DC braking(first set P.018, P.019) before startup It is suitable for small inertia load, and reversal may occur during startup.</p> <p>2: Revolving speed tracking startup: The inverter firstly judges the revolving speed and direction of the motor and then starts at the frequency corresponding to the tracked rotation velocity of the motor, and performs smooth startup of the motor in rotation without impact.It is suitable for the applications where large inertia is restarted due to transient power shutdown.In order to ensure the performance of the rotation velocity tracking startup, motor parameters (Group P1) should be set correctly.</p>					
P.016	Start frequency	0.00Hz~10.00Hz	0.00Hz	☆	
P.017	Start frequency holding time	0.0s~50.0s	0.0s	★	
<p>To ensure the torque at the time of startup, proper startup frequency shall be set. In addition, in order to set up magnetic flux when waiting for the startup of the motor, the startup frequency shall remain for a certain period of time before accelerating to the setup frequency.</p> <p>Start frequency P.016 is not affected by the lower frequency limit.If the frequency reference value (frequency source) is lower than the startup frequency, the inverter cannot start and will be in standby status.</p> <p>In positive&negative switching process, startup frequency retention time does not work.Startup frequency retention time is not included in the acceleration time,but included in the simple PLC running time.</p> <p>Example 1: P0.03=0 means the frequency source is digital reference. P0.08=2.00Hz means the digital setup frequency is 2.00Hz. P.016=5.00Hz means the startup frequency is 5.00Hz. P.017=2.0s means that the startup frequency retention time is 2.0s. In this case, the inverter will be in the standby status and its output frequency is 0Hz.</p> <p>Example 2: P0.03=0 means the frequency source is digital reference. P0.08=10.00Hz means the digital setup frequency is 10.00Hz. P.016=5.00Hz means the startup frequency is 5.00Hz. P.017=2.0s means that the startup frequency retention time is 2.0s.</p>					

Section V. Parameter Function Table

In this case, the inverter accelerates to 5.00 Hz and remains for 2 seconds, and then accelerates to the setup frequency 10Hz.					
P.018	Start dc braking current /pre-excitation current	0%~150%	0%	★	
P.019	Start dc braking time /pre-excitation time	0.0s~50.0s	0.0s	★	
<p>Pre-excitation is used to establish asynchronous motor magnetic field before startup, which would improve response speed.</p> <p>Start dc current braking is only valid when it is direct startup. Inverter first carries out dc braking according to the setup of start dc current braking , and then carries out operation after start dc braking time.</p> <p>If dc braking time is set to 0, inverter directly start without dc braking. The bigger the dc braking current is , the greater the braking force is.</p> <p>If start mode is asynchronous motor pre-excitation start, inverter first establish magnetic field through pre-excitation current setup, then start to run after pre-excitation time. If set pre-excitation time to 0, inverter would directly start without pre-excitation process.</p> <p>Start dc braking current/pre-excitation current is the relative percentage of rated current.</p>					
P.020	UP/DOWN key frequency accumulation function	close	0	1	★
		open	1		
P.021	UP/DOWN key single step length	0.00~10.00Hz	0.01Hz	★	
P.021 UP/DOWN key single step length : Increase or decrease the frequency by pressing the UP/DOWN key for one time.					
P.022	JOG key function selection	Jog running	0	0	★
		Switching between FWD & REV rotation	1		
		Clear UP/DOWN settings	2		
<p>It is used to set the functions of multifunctional JOG key.</p> <p>0: Jog running function</p> <p>1: Switching between forward and reverse rotation</p> <p>Switching the rotary direction of the motor via the JOG key on the keyboard is only enabled when the command source is "operation panel command".</p> <p>2: press JOG key can Clear UP/DOWN setting</p>					
P.023	STOP function	The stop function of STOP key is valid only in the keyboard control mode.	0	1	☆
		The stop function of STOP key is valid in the keyboard and terminal control mode.	1		
		The stop function of STOP key is valid in the keyboard and communication control mode.	2		
		The stop function of STOP key is valid in any control mode.	3		
To do Fault reset STOP key is valid in any control mode.					
P.024	Panel potentiometer section	0.00~100.00	3	☆	
P.025	Dead zone time of forward & reverse rotations	0.00s~3600.0s	0.0s	☆	
It refers to the transit time at the 0Hz output point when the inverter switches between forward rotation and reverse rotation. As shown in figure 5-15.					

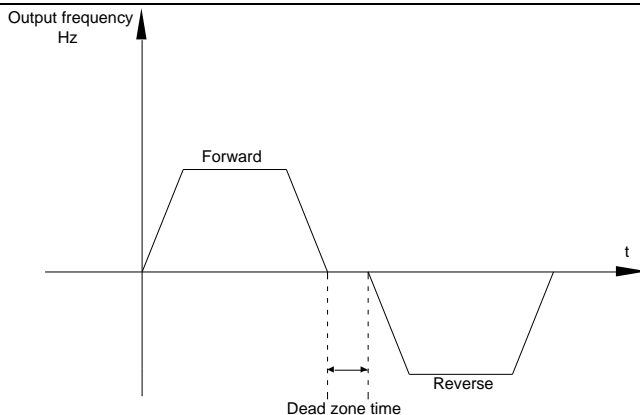

Fig.5-15 Rotation dead zone time schematic diagram

Below 15KW the Factory value is 0.0s; Above 18.5KW , Factory value is 1.0s

P.026	Terminal protection selection when operation	Invalid	0	1	☆
		Valid	1		
P.027	Set frequency below lower limit running mode	Run with frequency lower limit	0	0	☆
		stop	1		
		0 speed operation	2		
It is used to select the running status of the inverter when the set frequency is lower than the frequency lower limit. AE200H offers 3 kinds of running mode to meet all kinds of applications.					
P.028	Inverter type	G type(constant torque load type)	0	-	★
		P type(draught fan,pump load type)	1		
This parameter is only for the use of viewing the factory model. It is can not be modified. 0: It is applicable to the constant torque load of specified rated parameter 1: It is applicable to the variable torque load of specified rated parameter(draught fan,pump load type)					
P.029	Rated power	0.4kW~900.0kW	-		★
P.030	Rated frequency	0.01Hz~maximum frequency	-		★
P.031	Rated revolving speed	0rpm~36000rpm	-		★
Function codes above are motor nameplate parameters. No matter VF control or vector control is the chosen mode, users should accurately set the relating parameter according to the motor nameplate. For better VF or vector control performance, users should tune the motor parameter. The accuracy of the regulation results has intimate relationship with the accuracy of set motor nameplate parameters.					
P.032	Rated voltage	0V~460V	-		★
P.033	Rated current	0.1A~2000.0A	-		★
P.034	Asynchronous motor stator resistance	0.001Ω~65.535Ω	-		★
P.035	Asynchronous motor rotor resistance	0.001Ω~65.535Ω	-		★
P.036	Asynchronous motor leakage inductance	0.01mH~6553.5mH	-		★
P.037	Asynchronous motor mutual inductance	0.1mH~6553.5mH	-		★

Section V. Parameter Function Table

P.038	Asynchronous motor no load current	0.01A~655.35 A	-	★	
<p>P.032~P.038 are parameters for asynchronous motor. Generally, motor nameplate doesn't contain such parameters, users can get them through inverter auto tuning. Among them, 3 parameters (P.034~P.036) can be get through " asynchronous motor static tuning", while all the 5 parameters as well as encoder phase , current loop PI etc can be get through "asynchronous motor complete tuning". When change the motor rated power (P.029) or motor rated voltage (P.032), inverter would automatically modify the P.034~P.038 parameter value and restore them to common standard of Y series motor parameter.</p> <p>If the asynchronous motor is unable to be tuned, users could input above parameters with factory offered motor value.</p>					
P.039	Speed loop proportional gain 1	1~100	15	☆	
P.040	Speed loop integration time1	0.01s~10.00s	2.00s	☆	
P.041	Switching frequency1	0.00~P.044	5.00Hz	☆	
P.042	Speed loop proportional gain 2	0~100	10	☆	
P.043	Speed loop integration time 2	0.01s~10.00s	3.00s	☆	
P.044	Switching frequency 2	P.041~maximum frequency	10.00Hz	☆	
<p>Users could choose different speed loop PI parameters under different running frequency. When running frequency is less than the switching frequency(P.041), adjusting parameters for speed loop PI are P.039 and P.040. When running frequency is greater than the switching frequency (P.041), adjusting parameters for speed loop PI are P.042 and P.043. Speed loop PI parameters between switching frequency1 and switching frequency2 are two groups of linear switching. As shown in fig.5.2:</p>					
<p>Fig.5-2 PI parameter schematic diagram</p>					
<p>Users can adjust vector control speed dynamic response characteristics through setting proportional coefficient and integration time of the speed regulator.</p> <p>Both increasing proportional gain and reducing integration time can accelerate the speed loop dynamic response. But excessive proportional gain or insufficient integration time may led to system oscillation.</p> <p>Suggestions for regulating method:</p> <p>If the factory parameters can not meet the requirements, users can fine-tuning it on the basis of factory value parameters. First increase the proportional gain to restrain system oscillation, then reduce integration time so that system has fast response characteristic and smaller overshoot.</p> <p>Notice: Improper PI parameter setting may lead to excessive speed overshoot , even voltage fault during overshoot drop.</p>					
P.045	VC speed compensation	50%~200%	100%	☆	
P.046	Torque limit	0.0%~200%	150%	☆	
P.047	The curve shape of V/F	lineV/F curve(Common constant torque	0	0	☆

function	load)	1		
	The curve of V/F 2.0 reducing power (Centrifugal load of fan, water pump, etc)			

In the process of inverter deceleration, over-excitation control can restrain the rising of bus voltage to avoid over-voltage fault. The larger the over-excitation gain, the stronger the suppression effect.

In applications where over-voltage alarming easily occurs during deceleration process, users should increase over-excitation gain. Excessive over-excitation gain may lead to output current increasing, users should balance it during application.

It is recommended that over-excitation gain is set to 0 in applications where inertia is small, motor decelerates without voltage rising. For applications with braking resistor, 0 is also recommended for over-excitation gain.

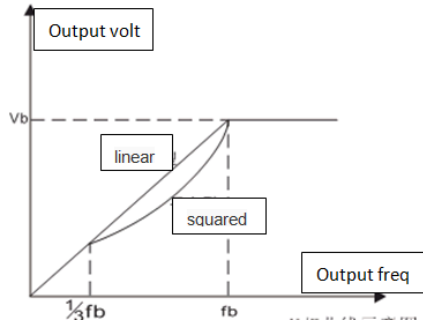

P.048	Torque boost value	0.0%(automatic torque boost)	0.0%	☆
		0.1%~30%		
P.049	Torque boost cut-off frequency	0.00%~50% Maximum frequency	20%	★

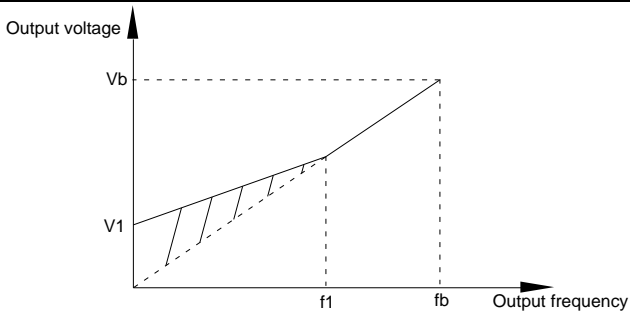

V1:Manual torque boost voltage Vb:Maximum output voltage

f1:Cutt-off frequency of torque boost fb:Rated running frequency

Fig. 5-3 Manual torque boost schematic diagram

To compensate the low frequency torque characteristics of V/F control, boost compensation should be made to inverter low frequency output voltage.

Torque hoist: it will be set according to the percentage of input rated voltage to the inverter. Below are explanations of setting torque increase:

- 1) When the torque hoist is set as 0.0%, the inverter will adopt auto torque hoist.
- 2) This parameter can be properly hoisted for small motor, while for large motor; the parameter can be

Section V. Parameter Function Table

properly decreased.				
3) If the torque hoist is set to be too large, the motor may be overheated, and the inverter may be over-current.				
Torque hoist cut-off frequency: As shown in Fig. 5.3, the torque hoist is valid when the cutoff frequency below this setting. Otherwise, the torque hoist will be invalid.				
P.050	V/F slip compensation gain	0%~200.0%	0.0%	☆
This parameter is only valid for asynchronous motor.				
VF slip compensation can compensate asynchronous motor speed deviation ,in this way , motor rotary speed could be maintained in basically stable state during load change. In general, 100% corresponds to the rated slip of the motor with rated load. For motor rated slip , it can be get through auto calculation of P1 motor rated frequency and rated revolving speed.				
The slip compensation gain adjustment may be performed referring to the following principle: When the load is rated load, and the slip compensation coefficient is set to 100%, the rotary speed of the motor is close to the reference speed.				
P. 051	Run with the least energy way	without	0	0 ☆
		with	1	
When the motor operates at a constant speed during no-load or light load The VFD automatically adjust the output voltage by detecting the load current and get the energy saving. It is especially effective for fans and pumps.				
P.052	Reserve	-	-	☆
P.053	S1 terminal function selection	0~25	1	★
P.054	S2 terminal function selection	0~25	2	★
P.055	S3 terminal function selection	0~25	3	★
P.056	S4 terminal function selection	0~25	7	★
P.057	S5 terminal function selection	0~25	4	★
P.058	S6 terminal function selection	0~25	5	★

These parameters are used to set digital multi-function input terminals, as shown in the table below:

Setting	Function	Specification explanation
0	No- function	Set useless terminals to "no function", in order to prevent misoperation.
1	Forward command (FWD)	The forward jog and reverse jog of the inverter are controlled via the external terminals.
2	Reverse command (REV)	
3	Three line running control	Set inverter running mode as three line control mode.For details please refer to function code P.060 (Terminal command mode).
4	FWD JOG command (FJOG)	FJOG refers to jog forward running, RJOG refers to jog reverse running. For jog running frequency, jog acc./dec. time please refer to P.099、 P.100、 P.101 for details.
5	REV JOG command (RJOG)	
6	Free stop	When this terminal command is valid, meaning that the inverter locks the output, the load will free stop according to the

		mechanical inertia.								
7	Fault reset(RESET)	When this terminal command is valid, inverter's fault can be reset. It has the same function with RESET key on the keyboard. This function can realize remote fault reset.								
8	External default normally open input	When the inverter detects that the signal occurs , it will report fault, and handle the fault according to the fault protection action mode..								
9	Frequency increment command	The given frequency is modified by an external terminal,UP is Frequency increment command, DOWN is Frequency decrement command. By Frequency Acc./dec setup reset,one can restore the frequency to the frequency given by the communication channel								
10	Frequency decrement command									
11	Frequency Acc./dec setup reset									
12	Multi-stage speed terminal1	The setting of 8-segment speeds can be realized by the combinations of the terminal status when the frequency source is "MS Speed". Refer to P.188~P.195 for details.								
13	Multi-stage speed terminal2									
14	Multi-stage speed terminal3									
15	Acc./dec.time selection terminal 1	It can realize 8 kinds of acc./dec. selection mode by combination status of this 2 terminals.								
16	Acc./dec.time selection terminal 2									
17	Acc./dec.time selection terminal 3	Acc./dec.time selection terminal 1	OFF	ON	OFF	ON	OFF	ON	OFF	ON
		Acc./dec. time selection terminal 2	OFF	OFF	ON	ON	OFF	OFF	ON	ON
		Acc./dec. time selection terminal 3	OFF	OFF	OFF	OFF	ON	ON	ON	ON
		Acc./dec. time selection	0	1	2	3	4	5	6	7
18	Closed loop failure	The PID is fault temporarily and the inverter maintains the current frequency output.								
19	Swing frequency pause	When this terminal command is valid, the inverter maintains the frequency output of the swing frequency center, and the swing frequency pauses.								
20	Swing frequency	Inverter Return to center frequency output								

Section V. Parameter Function Table

	reset	
21	Acc./dec forbidden	When this terminal command is valid, it can maintain the current frequency output while stopping.
22	terminal stop	Inverter can be stop by terminal, refer to P.080 for details.
23	The frequency Acc./dec setting is temporarily cleared	When this terminal command is valid, it clears the memorized PLC running phase and running time, and restores to the initial status of PLC running.
24	Terminal count	When the Terminal receives the digital input signal, the inverter will count.
25	Terminal count clear	To clear the built-in counter of the inverter.

P.059	S filter times	1~10	5	☆
-------	----------------	------	---	---

To set the filter time for S1-S6 terminal when sampling. Under the case of strong interference, this parameter shall be enlarged.

P.060	Terminal command mode	Two-line mode 1	0	0	★
		Two-line mode 2	1		
		Three-line mode 1	2		
		Three-line mode 2	3		

This parameter defines four different modes of controlling the forward and reverse rotations of the inverter via the external terminal.

0: Two-line mode 1:

This mode is the most commonly used forward/reverse rotation control mode. The forward/reverse rotation of the motor is decided by the S1, S2 terminal commands. The descriptions on the terminal running command are as shown as below:

Terminal	Set value	Description
S1	1	Forward(FWD)
S2	2	Reverse(REV)

Among them, S1, S2 are multi-function input terminal, level valid.

K1	K2	Command
OFF	OFF	Stop
ON	OFF	Forward(FWD)
OFF	ON	Reverse(REV)
ON	ON	Stop

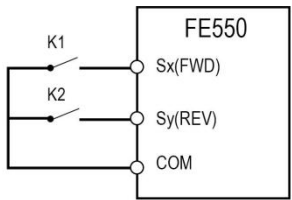

Fig. 5-6 Two-line control mode 1

1: Two-line mode 2:

In this operation mode, S1 terminal function is to enable operation, while S2 terminal function is to determine running direction. The descriptions on the terminal running command are as shown as below:

Terminal	Set value	Description
S1	1	Forward(FWD)
S2	2	Reverse(REV)

Among them , S1、S2 are multi-fuction input terminal, level valid

K1	K2	Command
OFF	OFF	Stop
OFF	ON	Stop
ON	OFF	Forward(FWD)
ON	ON	Reverse(REV)

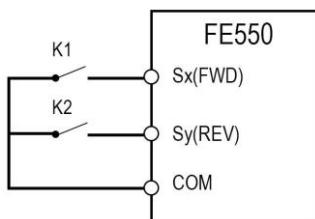

Fig. 5-7 Two-line control mode 2

2: Three-line mode1

In this operation mode, S1 terminal is the enable terminal, running direction controlled by S2. Sn is Normally closed input. The descriptions on the terminal running command are as shown as below:

Terminal	Set value	Description
Sx	1	Forward(FWD)
Sy	2	Reverse(REV)
Sn	3	Three-line running control

When in the need of running, users should first connect Sn terminal. Forward and reverse running is realized through the rising edge of Sx or Sy.

When in the need of stop, user should disconnect Sn terminal to meet the need. Among them, Sx、Sy、DIn are multi-function input terminal of S1~S10. Sx,Sy are of pulse valid, while Sn level valid.

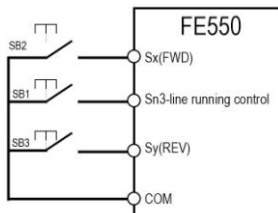

Fig. 5-8 Three-line control mode 1

Among them:

SB1: Stop button

SB2: Forward rotation button

SB3: Reverse rotation button

3: Three-line mode2

In this operation mode, Sn terminal is the enable terminal, Sx terminal function is to enable operation, while Sy terminal function is to determine running direction. The descriptions on the terminal running command are as shown as below:

Terminal	Set value	Description
S1	1	Forward(FWD)
S2	2	Reverse(REV)
Sn	3	Three-line running control

When in the need of running, users should first connect Sn terminal. S1 pulse rising edge gives running command signal, while S2 status gives running direction signal.

When in the need of stop, user should disconnect Sn terminal to meet the need. Among them, S1, S2, DI are multi-function input terminals. S1 is of pulse valid, while S2, DI is of level valid.

K	Description
0	Forward(FWD)
1	Reverse(REV)

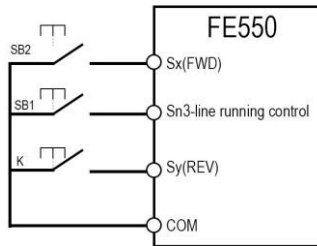

Fig. 5-9 Three-line control mode 2

Among them :

SB1: Stop button

SB2: Running button

K: Forward and reverse switch

P.061	Terminal UP/DOWN variation rate	0.01Hz/s~50.00Hz/s	0.50Hz/s	☆
It is used to set the frequency variation rate (frequency variation per second) when adjusting the set frequency with terminals UP/DOWN.				
P.062	FV curve 1 minimum input	0.00V~10.00V	0.00V	☆
P.063	FV curve 1 minimum input corresponding setup	-100.00%~100.0%	0.0%	☆
P.064	FV curve 1 maximum input	0.00V~10.00V	10.00V	☆
P.065	FV curve 1 maximum input corresponding setup	-100.00%~100.0%	100.0%	☆
P.066	FV filter time	0.00s~10.00s	0.10s	☆

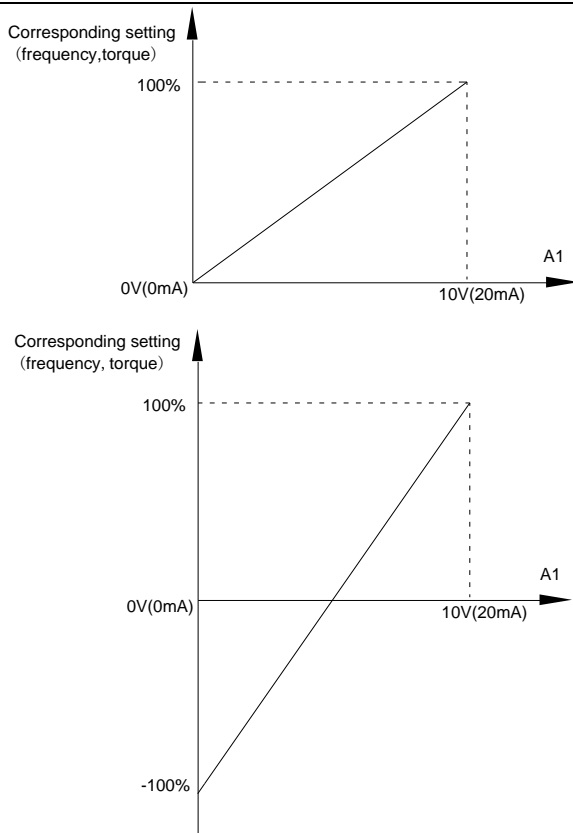

Fig. 5-10 Relationship between analog input and setup value

The parameters mentioned above define the relationship between analog input voltage and the analog input setup value.

When analog input voltage exceeds the setup "maximum input" limit, analog voltage is calculated as "maximum input". Similarly, when analog input is smaller than the setup "minimum input", analog voltage is calculated as minimum input or 0.0%.

FV used as current input terminal : 1mA current equals to 0.5V voltage.

FV input filtering time is used to set FV software filtering time. When field analog quantity is vulnerable, please increase the filtering time so that analog quantity tends to be stable. But excessive filtering time will lead to slow response time to analog detection. User should balance it according to practical application cases.

In various application cases, the nominal value corresponding to 100% of analog reference will be different. Refer to specific application description for the specific value.

Figure 5.10 shows typical setup cases.

P.067	FI curve 2 minimum input	0.00V~10.00V	0.00V	☆
-------	--------------------------	--------------	-------	---

Section V. Parameter Function Table

P.068	Fl curve 2 minimum input corresponding setup	-100.00%~100.0%	0.0%	☆
P.069	Fl curve 2 maximum input	0.00V~10.00V	10.00V	☆
P.070	Fl curve 2 maximum input corresponding setup	-100.00%~100.0%	100.0%	☆
P.071	Fl filter time	0.00s~10.00s	0.10s	☆

For function and usage of curve 2, please refer to description of curve 1, Fl Supports 0-20mA current input corresponding to 0-10V voltage.

P.072	Relay output selection (J1)	0-14	14	☆
P.073	Expansion card relay output selection(J2)	0-14	3	☆

Function selections are as follows:

Set value	Function	Description
0	No output	The output terminals have no function
1	Inverter in forward operation	When the inverter is forward running, ON signal is output.
2	Inverter in reverse operation	When the inverter is reverse running, ON signal is output.
3	Output fault(Stop fault)	When inverter fault happens and stops due to the fault , ON signal is output
4	Frequency level detection FDT output	please refer to P.110;P.111 for details
5	Frequency arrival	please refer to P.112 for details
6	Null speed operation (stop without output)	When inverter is in running status and output 0Hz , ON signal is output. When inverter is in stop status, OFF signal is output.
7	Frequency upper limit arrived	When the running frequency of the inverter reaches the frequency upper limit, it outputs ON signal.
8	Frequency lower limit arrived (stop without output)	When the running frequency of the inverter reaches the frequency lower limit, it outputs ON signal. And output OFF signal in stop status.
9	speed operation	When inverter is in running status and output more than 0Hz , ON signal is output.
10	booster bump function1	please refer to P.127--P.133 for details
11	booster bump function2	please refer to P.127--P.133 for details
12	Setup counting value arrived	please refer to P.157--P.160 for details
13	Setup counting value arrived alarm	please refer to P.157--P.160 for details
14	Inverter in running operation	When the inverter is running, ON signal is output.

P.074	FO output function selection	0-10	0	☆
-------	------------------------------	------	---	---

The corresponding value range is shown in the table below:

Section V. Parameter Function Table

Setup value	Function	Range
0	Running frequency	0~maximum output frequency
1	Setup frequency	0~maximum output frequency
2	Running speed	0~maximum output speed
3	Output current Output torque	0~200% of the rated current of the inverter
4	Output voltage Output power	0~ 150% of the rated voltage of the inverter
5	Output power	0~200% of the rated power of the inverter
6	Output torque	0~200% of the rated torque of the inverter
7	Analog FV input value	0-10V
8	Analog FI input value	0-20mA
9	Reserve	-
10	Reserve	-

P.075	Lower limit of FO	0%~100.0%	0.0%	☆
P.076	Lower limit of FO output	0.00V~10.00V	0.00V	☆
P.077	Upper limit of FO	0%~100.0%	100.0%	☆
P.078	Upper limit of FO output	0.00V~10.00V	10.00V	☆
P.079	Versions of the software	1.00~9.99	-	★

P.080	Stop mode	Speed-down to stop	0	0	☆
		Free stop	1		
<p>0: Deceleration to stop</p> <p>When the stop command is valid, the inverter will decelerate to stop according to the setup deceleration time.</p> <p>1: Free stop</p> <p>When the stop command is valid, the inverter will terminate the output immediately and the load will coast to stop according to the mechanical inertia.</p>					
P.081	DC braking initial frequency at stop	0.00Hz~maximum frequency	0.00Hz	☆	
P.082	DC braking waiting time at stop	0.0s~50.0s	0.0s	☆	
P.083	DC braking current at stop	0%~150%	0%	☆	
P.084	DC braking time at stop	0.0s~50.0s	0.0s	☆	
<p>DC brake initial frequency at stop: During the process of decelerating to stop, when the running frequency at stop reaches this frequency, it will start the process of DC brake.</p> <p>DC brake waiting time at stop: Prior to the beginning of DC brake at stop, the inverter will terminate the output, and then start DC brake after this delay time. It is used to prevent over current fault due to DC brake which starts at the time of higher velocity.</p>					

DC brake current at stop: The DC brake quantity added shall be set according to the percentage setting of the rated current of the inverter. The higher the brake current is, more powerful the brake effect is.

DC brake time at stop: It refers to the continuous DC brake time. If this DC brake time is set to 0, it indicates that there is no DC brake process, and the inverter will stop according to the setting process of decelerating to stop.

The process of DC brake at stop is as shown in Figure below.

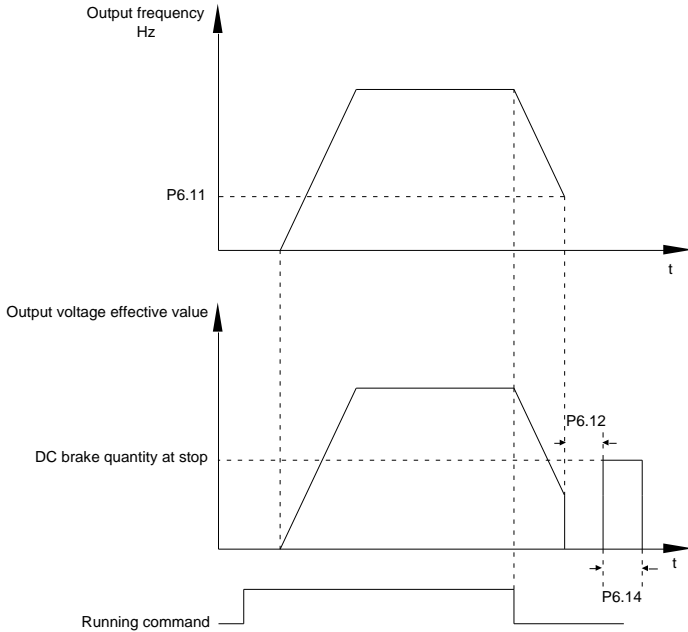

Fig.5-13 DC brake schematic diagram

P.085	LED running display parameter1	0000~FFFF	03FF	☆
-------	--------------------------------	-----------	------	---

It is a 16 bit binary number. If a digit is 1, it will be changed to the corresponding parameter, which can be viewed by pressing DATA key during inverter running. If a digit is 0, the corresponding parameter will not be displayed

BIT7	BIT6	BIT5	BIT4	BIT3	BIT2	BIT1	BIT0
Output torque	Output frequency	Running speed	Output currenry	Output voltage	Bus voltage	Setting frequency	Running frequency
BIT15	BIT14	BIT13	BIT12	BIT11	BIT10	BIT9	BIT8
Count value	Current Multi-velocity	FI	FV	Output terminal state	Input terminal state	PID Feedback	PID setting

The status of input and output terminals is displayed in hexadecimal. S1(J1) is low state. Such as input 3, S1,S2 connected , Other terminals disconnected please refer to P.97~P.98 for details.

If the above parameters need to be displayed during the operation, users can set their corresponding positions to 1 and then convert this binary number into decimal number and set it to P.085.

Section V. Parameter Function Table

P.086	LED stop display parameter	0000~FFFF	00FF	☆			
If the above parameters need to be displayed at the time of stop, it can set their corresponding positions to 1 and then convert this binary number into decimal number and set it to P.086.							
BIT7	BIT6	BIT5	BIT4	BIT3	BIT2	BIT1	BIT0
Fl	FV	PID Feedback	PID setting	Output terminal state	Input terminal state	Bus voltage	Setting frequency
BIT15	BIT14	BIT13	BIT12	BIT11	BIT10	BIT9	BIT8
reserve	reserve	reserve	reserve	reserve	reserve	Coult value	Current Multi-velocity
P.087	Reserve						
P.088	Inverter module radiator temperature	0.0℃~100.0℃	12℃	•			
It is used to display IGBT temperature. Different model's inverter module is set with different IGBT over temperature protection value.							
P.089	User password	0-65535	0	☆			
Set to any number other than 0, the password protection function will take effect immediately after exiting the editing state, Set to 0, the password protection function fails; Restoring the factory value can also clear the previously set password.							
P.090	Accumulative running time	0h~65535h	0h	•			
It is used to display the accumulated running time of the inverter. When the accumulated running time reaches P8.17 setup running time, the multifunctional digital output terminal(12) will output ON signal.							
P.091	The first fault type	0~24	-	•			
P.092	The second fault type	0~24	-	•			
P.093	The latest fault type	0~24	-	•			
It records the latest 3 fault types for the inverter: 0 means no fault and 1 to 51 correspond to ERR01 to ERR51.Refer to Chapter 6 for the details.							
Table of fault type :							
No.	Fault display	Fault type					
0	No fault	No fault					
1	1=Err01	Reserved					
2	2=Err02	Reserved					
3	3=Err03	Reserved					
4	4=Err04(OC1)	Acceleration over current					
5	5=Err05(OC2)	Deceleration over current					
6	6=Err06(OC3)	Constant speed over current					
7	7=Err07(OU1)	Acceleration over voltage					
8	8=Err08(OU2)	Deceleration over voltage					
9	9=Err09(OU9)	Constant speed over voltage					
10	10=Err10(UV)	Control power supply fault					
11	11=Err11(OL1)	Motor overload					

Section V. Parameter Function Table

12	12=Err12(OL2)	Inverter overload
13	13=Err13	Reserved
14	14=Err14(SP0)	Output phase lack
15	15=Err15	Reserved
16	16=Err16(OH2)	Inverter overheating
17	17=Err17(EF)	External equipment fault
18	18=Err18(CE)	Communication fault
19	19=Err19(ItE)	Current inspection fault
20	20=Err20(tE)	Motor tuning fault
21	21=Err21(EEP)	EEPROM read & write fault
22	22=Err22(PIDE)	PID feedback loss during operation fault
23	Reserved	Reserved
24	Reserved	Reserved

P.094	Third fault frequency	The latest fault frequency	•
P.095	Third fault current	The latest fault current	•
P.096	Third fault bus voltage	The latest fault bus voltage	•

P.097	Third fault input terminal	The latest fault digital input terminal status, order as below:						•
		BIT5	BIT4	BIT3	BIT2	BIT1	BIT0	
		S6	S5	S4	S3	S2	S1	
		When input terminal status is ON, it's corresponding binary digit is 1. OFF corresponds to 0. The status are converted to decimal display.						

P.098	Third fault output terminal	The latest fault digital output terminal status, order as below :				•
		BIT3	BIT2	BIT1	BIT0	
				J2	J1	
		When output terminal status is ON, it's corresponding binary digit is 1. OFF corresponds to 0. The status are converted to decimal display.				

P.099	Jog running frequency	0.00Hz~maximum frequency(P.004)	5.00Hz	☆
P.100	Jog acceleration time	0.0s~3600.0s	20.0s	☆
P.101	Jog deceleration time	0.0s~3600.0s	20.0s	☆

It defines the reference frequency and acc. / dec. time of the inverter at the time of jogging.
 The jog process is started and stopped according to direct startup mode and decelerate to stop mode(P.080=0).

Below 5.5KW the Factory value is 10.0s; 7.5KW—30KW is 20.0s;above 37KW is 40.0s.

P.102	Hopping frequency 1	0.00Hz~P.004 maximum frequency	0.00Hz	☆
-------	---------------------	--------------------------------	--------	---

P.103	Hopping frequency amplitude	0.00Hz~ P.004 frequency	maximum	0.00Hz	☆
-------	-----------------------------	----------------------------	---------	--------	---

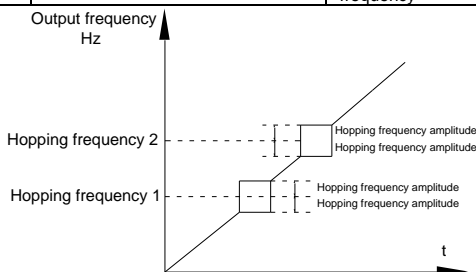

Fig.5-14 Skip frequency schematic diagram

When set frequency is within the range of hopping frequency, the actual running frequency will run close to the set frequency of hopping frequency. Inverter can avoid load mechanical resonance by setting hopping frequency.

AE200H can set 2 hopping frequency points,if both of them are set to 0, then the hopping frequency function is canceled.Hopping frequency and hopping frequency amplitude schematic is shown in Fig5-14.

P.104	Swing frequency	0.0~100.0%	0.0%	☆
P.105	Burst hopping frequency	0.0~50.0%	0.0%	☆
P.106	Swing frequency rising time	0.1~3600s	5.0s	☆
P.107	Swing frequency dropping time	0.1~3600s	5.0s	☆

This function is suitable for the industries such as the textile, chemical fiber etc., and the occasions which need traverse, winding function. The swing frequency function refers to that the output frequency of the frequency inverter swings up and down with the set frequency as the center and the track of the operating frequency in the timeline is shwon below, where the swinging scope is set by the P.104. When the P.104 is set to 0, that is, the swing frequency is 0, then the swing frequency will not work.

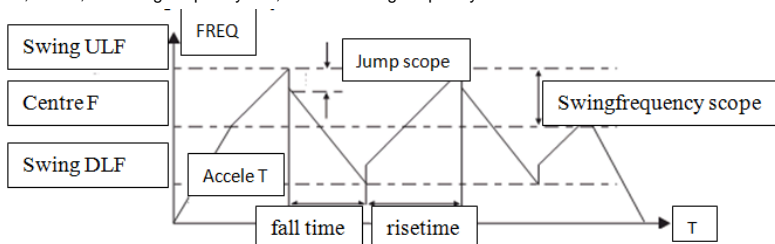

Schematic diagram of swing frequency operation

Swing frequency scope: the swing running frequency is controlled by the upper and lower frequency. The swing scope relative to center frequency: $\text{swing scop AW} = \text{Center frequency} \times \text{swing frequency (P.104)}$. Hopping frequency= $\text{swing scop AW} \times \text{hopping frequency scope (P.105)}$. That is, in the swing frequency operation, the value of the hopping frequency to the swing scope.

Swing scop risetime:the time used for the swing frequency to run form the lowest point to the highest point.

Swing scop fall time:the time used for the swing frequency to run form the highest point to the lowest point.

Section V. Parameter Function Table

P.108	Automatic fault reset times	0~3	0	☆
P.109	Automatic fault reset interval	0.1~100.0s	1.0s	☆
<p>Number of fault resetting: When the frequency inverter selects to automatic fault resetting, it will be used to set the number of automatic resetting. If this value is exceeded then the frequency inverter will be standby for the failure to wait for the repair. Automatic fault resetting interval setting: to select the interval from the occurrence of the fault to the automatic reset action.</p>				
P.110	FDT Electric-level	0.0~P.004 (Maximum frequency)	50Hz	☆

To set FDT Electric-level which is as shown below:

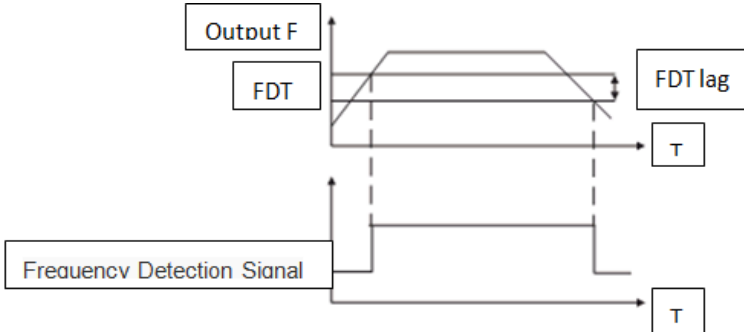

P.111	FDT delay detection	0.0~100.0%	5.0%	☆
P.112	Frequency arrival detection	0.0~100.0%	0.0%	☆

When the output frequency of the frequency inverter reaches the set frequency value, this function can adjust its detection amplitude of it which is shown as follows:

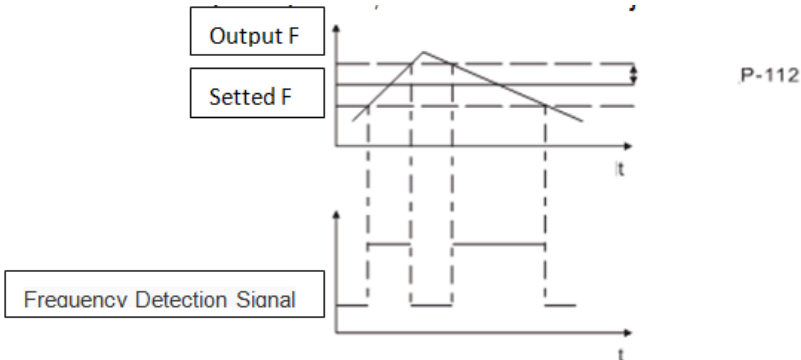

P.113	Brake threshold voltage	115.0%~140.0% (380V)	130.0%	☆
		115.0%~140.0% (220V)	120.0%	

This function is to set the starting bus voltage of the dynamic braking and the proper adjustment of this value can effectively brake the load.

P.114	Load speed coefficient	0.1~999.9%(machine speed =120*running frequency *(p.114)/ Motor series	100%	☆	
<p>When display of the load speed is necessary, P.114 is used to adjust the corresponding relationship between inverter frequency output and load speed.</p> <p>Mechanical speed = 120 * Operating frequency * P.114 / number of motor poles, and this function code is used to correct the speed scale display error, which has no effect on the actual speed.</p>					
P.115	PID reference source	P.116 setup	0	0	☆
		FV	1		
		FI	2		
		Communication	3		
		MS command	4		
		AI3(Potentiometer)	5		
<p>When the frequency source selects PID, that is, P.003 = 5, then the PID function will work. This parameter determines the target quantity given channel of process PID. The set target quantity of the process PID is the relative value and set 100% corresponds to 100% of the feedback signal of the controlled system. The system is always operated according to the relative value (0 ~ 100.0%). Note: multi-segment given can be achieved through the setting of SPD parameters.</p>					
P.116	PID reference value	0.0%~100.0%	50.0%	☆	
<p>It is used to select target parameter reference channel of process PID.</p> <p>Set target value of process PID is a relative value, set range is 0.0%~100.0%. PID feedback value is a relative value as well, PID play the role of making the two relative value the same.</p> <p>This parameter will need to be set when P.115 = 0 is selected that is the target source is given. At this point the parameters and keyboard UP / DOWN binding can directly modify PID set value y through the keyboard UP / DOWN.</p> <p>The fiducial value of this parameter is the feedback amount of the system.</p> <p>PID function</p> <p>The diagram illustrates a PID control loop. It starts with a 'Given value' input, which is compared with a feedback signal 'F' at a summing junction. The resulting error signal is processed by a 'PID' block, which outputs 'Set F'. This signal then goes through an 'algorithm' block, followed by a motor symbol 'M' and a 'P' (position) output. A feedback path from the motor output goes through a 'filter' block to produce the feedback signal 'F'.</p>					
P.117	PID feedback source	FV	0	0	☆
		FI	1		
		FV+FI	2		
		Communication	3		
<p>It is used to select the feedback channel of PID</p> <p>Note: the given channel and feedback channel can not coincide, otherwise, PID can not be effectively controlled.</p> <p>Feedback value of process PID is a relative value, set range is 0.0%~100.0%.</p>					
P.118	PID action direction	Positive action	0	0	☆

Section V. Parameter Function Table

		Negative action	1		
<p>Positive action: If the feedback signal is smaller than the PID reference signal, it is required to boost the output frequency of the inverter to make PID reach balance. The winding tension PID control is such a case.</p> <p>Negative action: If the feedback signal is smaller than the PID reference signal, it is required to decrease the output frequency of the inverter to make PID reach balance. The unwinding tension PID control is such a case.</p> <p>This function is influenced by function 35, please pay attention during operation.</p>					
P.119	Proportional gain K_{p1}	0.0~100.0	1.00	☆	
P.120	Integration time T_{I1}	0.01s~10.00s	0.10s	☆	
P.121	Differential time T_{d1}	0.00~10.000	0.000s	☆	
<p>Proportional gain K_{p1}: the parameter determines the adjustable strength of PID regulator. The larger P is, the greater the adjustable strength will be. When the parameter is set to 100.0, it means that when the deviation between PID feedback value and reference value is 100.0%, the range for the PID regulator to regulate the output frequency commands is the maximum frequency (integration effect and differential effect are omitted).</p> <p>Integration time T_{I1}: determines the strength of PID integration regulation. The shorter the integration time, the greater adjustable strength will be. Integration time means that when the deviation between PID feedback value and reference value is 100%, the adjustment by the integration regulator (proportional effect and differential effect are omitted) after continuous adjustment in this period reaches the maximum frequency.</p> <p>Differential time T_{d1}: determines the degree of adjustment that PID regulator performs on the derivation between PID feedback value and reference value. Differential time means that if the feedback value changes 100% within this time, the adjustment by the differential regulator (proportional effect and differential effect are omitted) will reach the maximum frequency. The longer differential time is, the higher the degree of adjustment will be.</p>					
P.122	sampling period (T)	0.01~100.00s	0.10s	☆	
<p>Sampling period (T): refers to the sampling period of the feedback amount, which is operated one time by the regulator in every sampling period. The longer the sampling period, the slower the response.</p>					
P.123	PID deviation limit	0.0%~100.0%	0.0%	☆	
P.124	PID feedback loss detection value	0.1%~100.0%	0.0%	☆	
P.125	PID feedback loss detection time	0.0s~3600.0s	1s	☆	
<p>This function is used to judge if PID feedback has been lost.</p> <p>When PID feedback value is less than P.124 set value, and lasted for more than P.125 set value, inverter fault alarm. Fault No. 17= E.PID.</p>					
P.126	Waking pressure	0.0%~100.0%	20%	☆	
P.127	PID stop operation	Stop without operation	0	0	☆
		Stop with operation	1		

Section V. Parameter Function Table

It is used to select if PID keeping operation under PID stop status. Generally P.127=0 in stop status.					
P.128	Dormancy pressure	0.0%~100.0%	80%	☆	
P.129	Sleep delay time	0.0s~6000.0s	0.2s	☆	
<p>This group of function codes are used to realize sleep and wake up function.</p> <p>During operation: when set frequency is less than or equals to sleep frequency, inverter would step into sleep state and stop after sleep delay time P.129.</p> <p>If inverter is in sleep state and current running command is valid, when set frequency is no less than P8.49 wake-up frequency, inverter will start to run after P8.50 wake-up delay time.</p> <p>Generally, please set wake-up frequency no less than sleep frequency. Sleep function and wake-up function are valid when both wake-up frequency and sleep frequency are set to 0.00 Hz.</p> <p>When enabling sleep function(frequency source : PID) , PID calculation selection in sleep state is influenced by function code P.127 (P.127=1).</p>					
P.130	Wake up delay time	0.0s~6000.0s	0.2s	☆	
P.131	Waiting time for auxiliary pump to start	0.0s~6000.0s	0.0s	☆	
P.132	Waiting time for auxiliary pump to stop	0.0s~6000.0s	0.0s	☆	
P.133	Sleep frequency	0.00Hz~wake-up frequency(P.005)	0.00Hz	☆	
<p>In PID mode, the application of each parameter.</p> <p>The usage for auxiliary pump 1, 2 :</p> <ol style="list-style-type: none"> 1. First is to select the number of auxiliary pumps, and then the J1, J2 are selected as the corresponding auxiliary pump function. 2. Adding pump: When the operating frequency reaches the upper limit frequency. If then the PID given source y value is still greater than the feedback source L value, a auxiliary pump will be started after a certain period of time through the external terminal. This wait interval is the "auxiliary pump open-wait time". Reducing pumps:When the operating frequency reaches the lower limit frequency. If the PID given source value is still less than the feedback source value, a auxiliary pump will be closed after a certain period of time through the external terminal. This wait interval is the "auxiliary pump close-wait time". Opening sequence: J1 first and then J2 Closing sequence:J2 first and then J1 3. During the open-close waiting time of the auxiliary pump, if the condition is not satisfied, the time will be recalculated,. But the auxiliary pump which has been opened will not be closed. 4. During sleep, the auxiliary pump will be closed. <p>The usage of recovery pressure, sleepy pressure:</p> <ol style="list-style-type: none"> 1. Enable the "Sleepy Enable" first. 2. In the case of positive characteristic, the frequency inverter is in the awake state. If the PID feedback source value is greater than the value of the sleepy pressure, it will enters into the zero frequency operation state after a period of wait time. This waiting time is "sleep delay time". 3. In the case of positive characteristics, the frequency inverter is in the awake state. If the PID feedback source value is less than the value of the wake pressure, it will restore the non-zero frequency operation state. This wait time is "recovery delay time". 4. During the two delay periods, the time is recalculated as long as the condition is not satisfied. 					
P.134	Motor overload protection selection	Invalid	0	1	☆
		General motor (with low speed compensation)	1		
		Variable frequency motor (without low speed compensation)	2		

Section V. Parameter Function Table

0.: There is no motor overload protection characteristics (careful use) when the frequency inverter has no overload protection on the load motor.

1.: As the cooling effect of the ordinary motor in the low-speed is poor, the corresponding electronic thermal protection value will be also adjusted appropriately. Here the low-speed compensation characteristics mentioned, is to lower the overload protection threshold value of the motor with the operation frequency lower than 30Hz.

2.: As the cooling of the special motor of the frequency inverter is not affected by the rotate speed, so there is no need to have the protective value adjustment during the low-speed operation.

P.135	Motor overload protection current	20.0%~120.0%	100%	☆
-------	-----------------------------------	--------------	------	---

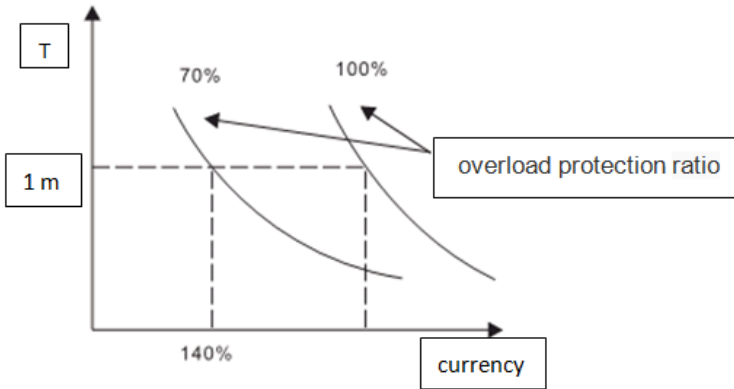

This value can be determined by the following formula:

$$\text{Motor overload protection current} = (\text{maximum allowable load current} / \text{frequency inverter rated current}) * 100\%.$$

In general, the maximum allowable load current is defined as the rated current of the load motor. When the rated current of the load motor does not match the rated current of the frequency inverter, the setting of the values of P.134 to P.135 can achieve the overload protection of the motor.

P.136	Instantaneous power down and frequency reduction	70.0%~110.0%	80%	☆
P.137	Instantaneous power down frequency drop rate	0~50Hz	0Hz	☆

When the instantaneous power-down rate is set to be as 0, the instantaneous power-down restart function is invalid. Instantaneous power-down reduced frequency point refers to that when the bus voltage reduces to the instantaneous power-down reduced frequency point after the disconnection of the power grid, the frequency inverter will start to lower the operation frequency according to the descent rate (P.137) of the instantaneous power-down frequency to let the motor in the power status. The feedback power is made to maintain the bus voltage, to ensure the normal operation of the inverter until the power of the frequency inverter is on.

Note: Proper adjustment of these two parameters, can achieve the power grid switching well, which will not cause the frequency inverter protection to cause the production downtime.

P.138	overvoltage stall property	Invalid	0	0	★
		Valid	1		
P.139	Overvoltage stall protection voltage	110%~150%(380V)	120%	☆	

		110%~150%(220V)	115%		
<p>During the deceleration of the inverter, the actual descent rate rate of the motor rotate speed may be lower than the output frequency, due to the influence of the load inertia. At this time, the motor will feed the power to the frequency inverter, causing the bus voltage of the frequency inverter to rise. If the measures are not taken, the bus over-voltage fault caused will cause the tripping operation of the frequency inverter.</p> <p>The overvoltage stall protection function can detect the bus voltage during the operation of the frequency inverter and have the comparison with the stall overpressure point defined by the P.139 (relative to the standard bus voltage). If it exceeds the stall overpressure point, the output frequency of the frequency inverter will stop the decreasing. When the bus voltage is detected again to be lower than the stall overpressure point, it will continue the deceleration operation as shown below:</p>					
P.140	Automatic current limiting level	100~200%	160%(G) 120%(P)	☆	
<p>During the operation of the frequency inverter, the actual raising rate of the motor rotate speed is lower than the rising rate of the output frequency due to the excessive load. If the measures are not taken, the bus over-current fault caused will cause the tripping operation of the frequency inverter.</p> <p>The overcurrent stall function can detect the putput current in the operation of the frequency inverter and have the comparison with the current-limiting level point defined by P.140. If the current-limiting level point is exceeded, the output frequency of the frequency inverter will decrease according to the descent rate of the over-current frequency. When the output current is detected again to be lower than the current-limiting level point, the normal operation will be restored.</p>					
P.141	Frequency drop rate during current limiting	0~100Hz/s	10Hz/s	☆	
P.142	Local address	1-247, 0 is broadcast address	1	☆	
<p>When the master is in the preparation of the frame, while the slave address is set to 0, that is, the broadcast address. All the slaves on the MODBUS bus will accept the frame, but the slaves will not response. Note that the slave address can not be set to be as zero. The master communication address is unique in the communication network, which is the basis to achieve the point to point communication of the upper motor and the inverter.</p>					
P.143	Baud rate	1200BPS	0	3	☆
		2400BPS	1		
		4800BPS	2		

Section V. Parameter Function Table

		9600BPS	3		
		19200BPS	4		
		38400BPS	5		

This parameter is used to set the message transmission rate between the motor and the inverter. Note that the set baud rate upper computer and the frequency inverter must be consistent, otherwise, the communication can not be carried out. The higher the baud rate, the faster the communication speed.

P:144	Data format	Without calibration (8-N-1) for RTU	0	0	☆
		Even parity calibration(8-E-1) for RTU	1		
		Uneven parity calibration(8-O-1) for RTU	2		
		Without calibration (8-N-2) for RTU	3		
		even parity calibration(8-E-2) for RTU	4		
		Uneven parity calibration(8-O-2) for RTU	5		
		Without calibration (7-N-1) for ASCII	6		
		even parity calibration(7-E-1) for ASCII	7		
		Uneven parity calibration(7-O-1) for ASCII	8		
		Without calibration (7-N-2) for ASCII	9		
		even parity calibration(7-E-2) for ASCII	10		
		Uneven parity calibration(7-O-2) for ASCII	11		
		Without calibration (8-N-1) for ASCII	12		
		even parity calibration(8-E-1) for ASCII	13		
		Uneven parity calibration(8-O-1) for ASCII	14		
		Without calibration (8-N-2) for ASCII	15		
		even parity calibration(8-E-2) for ASCII	16		
Uneven parity calibration(8-O-2) for ASCII	17				

The data format set by the motor and by the frequency inverter must be the same, otherwise, the communication can not be carried out.

11-bits (for RTU)

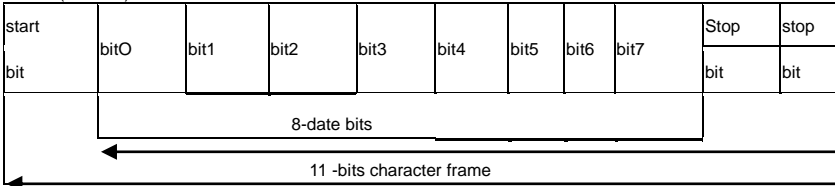

Data format: 8-N-2

Data format: 8-E-1

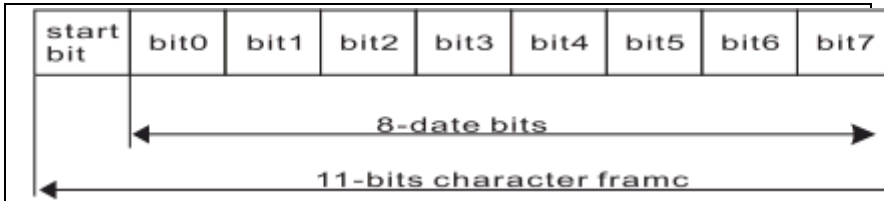

Data format: 8-0-1

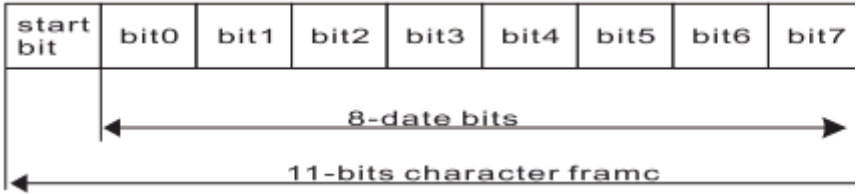

10-bits (for ASCII)

Data format: 7-N-2

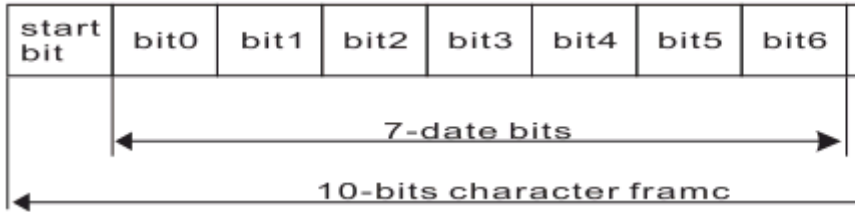

Data format: 7-E-1

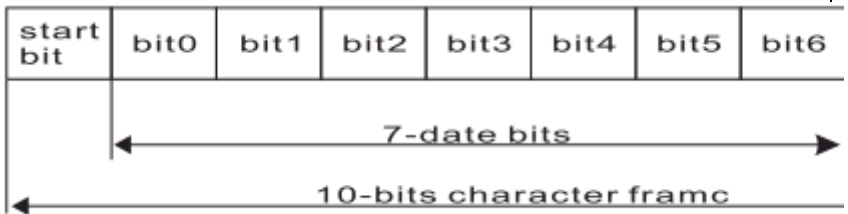

Data format: 7-0-1

Section V. Parameter Function Table

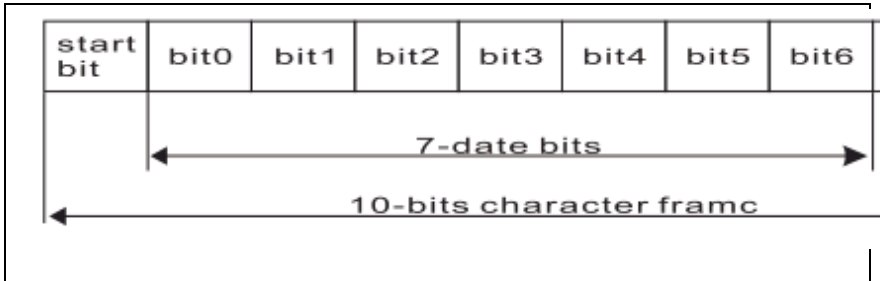

P.145	Response delay	0ms-20ms	5ms	☆	
<p>Response delay: refers to the middle interval time from the end of the data reception of the frequency inverter to sending the response data to the upper computer. If the response delay is less than the system processing time, the response delay shall be subject to the system processing time. If the response delay is longer than the system processing time, the system will delay the waiting time after the completion of the processing of the data of the system. The data is sent to the upper computer until the response delay time is reached.</p>					
P.146	Excessive communication time	0.0(invalid), 0.1s-100.0s	0.0	☆	
<p>When the function code is set to be as 0.0S, the communication timeout parameter is invalid. When the function code is set to be a valid value, where the interval between the two communication exceeds the communication timeout period, the system will report a communication error (CE). Normally, it is set to be invalid. If this parameter is set in the continuous communication system then the communication status can be monitored.</p>					
P.147	Communication fault	Alarm and Free deceleration stop	0	1	☆
		No Alarm and Continue running	1		
		No Alarm and Stop by shutdown (communication mode)	2		
		No Alarm and Stop by shutdown (all mode)	3		
P.148	Transmission response	response	0	0	☆
		No response	1		
<p>When the function code is set to be 0, the frequency inverter response all the read and write commands of the upper computer. When the function code is set to be 1, the frequency inverter response only the read command of the upper computer, and will not response to the write command. In this way, the communication efficiency can be improved.</p>					
P.149	Low frequency threshold for suppressing oscillation	0~500.0	15	☆	
P.150	High frequency threshold for suppressing oscillation	0~500.0	15	☆	
<p>Most motor will have the current oscillation in some frequency segment cause that the motor can not run stably and even can cause the overcurrent o inverter. When P.153 = 0, the enable will suppress the oscillation. When the P.149, P.150 are set small, the oscillation suppression effect is obvious where the current increase</p>					

Section V. Parameter Function Table

is more obvious. When it is set to be larger, the oscillation suppression effect will be weaker.							
P.151	suppressing oscillation limit	0~100.0		20	☆		
The voltage raising value during the restrain oscillation can be limited by setting the P.151.							
P.152	suppressing oscillation High and low frequency boundary frequency	0.00Hz~P.004(Maximum frequency)		12.5Hz	☆		
P.152 is the demarcation point of function codes P.149 and P.150.							
P.153	suppressing oscillation	Valid	0	0	☆		
		Invalid	1				
suppressing oscillation function is for VF control. The ordinary motor often has the current oscillation phenomenon in the no-load or light load operation, which will cause the abnormal operation of the motor and make the frequency inverter over-current seriously. When P.153 = 0, it is enabled to restrain the oscillation and the frequency inverter will have the restrain on the oscillation of the motor according to the P.149 ~ P.152 parameters.							
P.154	PMM	0~122		0	★		
Single digit : 0, PWM waveform five-stage and seven-stage automatic switching 1, seven-stage in the whole process 2, five-stage in the whole process Ten digit: 0, no modulation 1, overmodulation part open 2, over-modulation all open Hundred digit: 0, no function							
P.155	Non-loaded current compensation coefficient	0~9.99		0.5	☆		
P.155 can mainly compensate the torque size in the vector mode and within the 1Hz of the rotate speed and in general occasion the default value is Ok.							
P.156	Si Terminal inverting logic selection	Binary D0-D5 correspond to S1-S6		0	☆		
This function is used to select whether the S1 ~ S6 multi-function terminal is valid in disconnection. S1 ~ S6 corresponds to the binary bit DO ~ D5, which will be reversed when they are 1, that is, open valid for the disconnection. Example: If want to set the S2 valid for the disconnection, it need to set the P.156 parameter value to the weight of S2, ie P.156 = 2; If want to set the S2,S5 are valid for the disconnection, it need only to set the P.156 as the sum of the weights of S2 and S5, that is, P.156 = 18							
Multi-function terminals		S6	S5	S4	S3	S2	S1
Binary bit		D5	D4	D3	D2	D1	D0
D0~D5setting value		1	1	1	1	1	1
S1~S6weight		32	16	8	4	2	1
P.157	Current count value	0~65000		0	☆		
This parameter sets the current count value of the counter, and the external count pulse signal increments the parameter upwards.							
P.158	the threshold value in the counter	0~65000		100	☆		
This function is used to set the prevalue of the counter. When the count value is equal to the count prevalue,							

Section V. Parameter Function Table

the system responds according to the setting of P.160.					
P.159	Count alarm	0~65000	1	☆	
This function is used to set the counter's prewarning value to do a better preparation of the next stage before the arrival of the counter. When the counting arrival at the prewarning value, the system can output signal through the relay J1, J2 (P.072-P.073 set to 13).					
P.160	Count to action	Stop outputting messages	0	0	☆
		continue outputting messages	1		
This function is used to set the frequency inverter output selection when the count value reaches the count prevalue.					
P.161	PLC running mode	PLC operation mode	0	0	☆
		Continuous circulation	1		
		Single running stop	2		
		Single running end remaining final value	3		
<p>Simple PLC command can be used on two occasions: frequency source, VF separation voltage source.</p> <p>Fig 5-30 is the schematic diagram of simple PLC that used as frequency source. Positive & negative of PC.00~PC.15 determines the running direction.</p> <p>PLC has 3 running modes as frequency source (VF separation voltage source is not provided with the 3 modes):</p> <p>1: Continuous circulation Upon completion of one single cycle of the inverter, it will enter next cycle and not stop until stop command is given.</p> <p>2: Single running stop Upon completion of one single cycle of the inverter, it will stop automatically and will not start until running command is given again.</p> <p>3: Single running end remaining final value Upon completion of one single cycle of the inverter, the inverter will remain the running frequency and direction of last one phase. After the inverter restarted upon stop, it will run from the initial status of PLC.</p>					

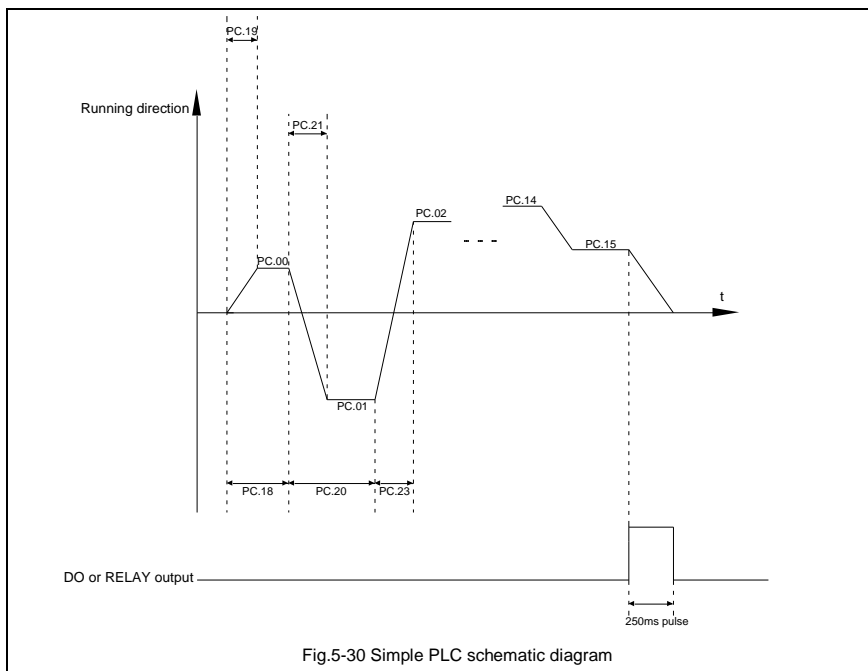

Fig.5-30 Simple PLC schematic diagram

P.162	PLC power off memory selection	Power off without memory	0	0	☆
		Power off with memory	1		
PLC stop memory refers to the record of PLC running stage and running frequency of the time before. Next time PLC continues to run from the memory stage. If is set to 0, PLC process would restart upon power-on.					
P.163	Running time unit	S(second)	0	0	☆
		M(minute)	1		
P.164	PLC 0segment running time	0.0s(h) ~ 6000.0s(h)			2.0s(h) ☆
P.165	PLC 1segment running time	0.0s(h) ~ 6000.0s (h)			2.0s(h) ☆
P.166	PLC 2segment running time	0.0s(h) ~6000.0s (h)			2.0s(h) ☆
P.167	PLC 3segment running time	0.0s(h) ~ 6000.0s (h)			2.0s(h) ☆
P.168	PLC 4segment running time	0.0s(h) ~ 6000.0s (h)			2.0s(h) ☆
P.169	PLC 5 segment running time	0.0s(h) ~ 6000.0s (h)			2.0s(h) ☆
P.170	PLC 6segment running time	0.0s(h) ~ 6000.0s (h)			2.0s(h) ☆
P.171	PLC 7segment running time	0.0s(h) ~ 6000.0s (h)			2.0s(h) ☆
P.172	acceleration time and deceleration time	0.0~7777 Unit: Acceleration and deceleration of the Unit section Tenth: Acceleration and deceleration of the first section Hundreds: Acceleration and deceleration			0

Section V. Parameter Function Table

		of the second section Thousands: Acceleration and deceleration of the third section 0: Acceleration and deceleration time is 0 1: Acceleration and deceleration time is 1 2: Acceleration and deceleration time is 2 3: Acceleration and deceleration time is 3 4: Acceleration and deceleration time is 4 5: Acceleration and deceleration time is 5 6: Acceleration and deceleration time is 6 7: Acceleration and deceleration time is 7		☆
P.173	acceleration time and deceleration time 2	0.0~7777 Unit: Acceleration and deceleration of the fourth section Tenth: Acceleration and deceleration of the fifth section Hundreds: Acceleration and deceleration of the sixth section Thousands: Acceleration and deceleration of the seventh section	0	☆
P.174	Acceleration time 1	0.1s~3600.0s	-	☆
P.176	Deceleration time 1	0.1s~3600.0s	-	☆
P.176	Acceleration time 2	0.1s~3600.0s	-	☆
P.177	Deceleration time 2	0.1s~3600.0s	-	☆
P.178	Acceleration time 3	0.1s~3600.0s	-	☆
P.179	Deceleration time 3	0.1s~3600.0s	-	☆
P.180	Acceleration time 4	0.1s~3600.0s	-	☆
P.181	Deceleration time 4	0.1s~3600.0s	-	☆
P.182	Acceleration time 5	0.1s~3600.0s	-	☆
P.183	Deceleration time 5	0.1s~3600.0s	-	☆
P.184	Acceleration time 5	0.1s~3600.0s	-	☆
P.185	Deceleration time 5	0.1s~3600.0s	-	☆
P.186	Acceleration time 5	0.1s~3600.0s	-	☆
P.187	Deceleration time 5	0.1s~3600.0s	-	☆
AE200H offers 7 groups of speed-up/speed-down time.				
P.188	MS command 0	-100.0%~100.0%	0.0%	☆
P.189	MS command 1	-100.0%~100.0%	0.0%	☆
P.190	MS command 2	-100.0%~100.0%	0.0%	☆
P.191	MS command 3	-100.0%~100.0%	0.0%	☆

P.192	MS command 4	-100.0%~100.0%	0.0%	☆
P.193	MS command 5	-100.0%~100.0%	0.0%	☆
P.194	MS command 6	-100.0%~100.0%	0.0%	☆
P.195	MS command 7	-100.0%~100.0%	0.0%	☆

MS speed command can be used on three occasions: frequency source, VF separation voltage source, process PID set source.

Dimension of MS speed command is a relative value ranging from -100.0% to 100.0%. When used as command source, it's the percentage of maximum frequency. When used as VF separation voltage source, it's the percentage of motor rated voltage. When used as PID set source, dimension conversion is not needed during the process.

MS command should be selected according to the different states of multi-function digit S terminals. MS symbols determine the direction of operation. If it is negative value, the frequency settin 100.0% will correspond to the maximum frequency (P.004). The 3 multifunction input terminals such as S1, S2, S3 as the PD terminals 1, 2, 3(12,13,14, respectively,corresponding to parameters P.053, P.054, P.055) and 8 segments speed can be selected through the composite encoding of S1, S2, S. When S1 = S2 = S3 = OFF, the frequency input mode is selected by code P.003. When not all the S1, S2, S3 terminals are OFF, the SPD will run. The priority of SPD is higher than the frequency input of keyboard, analog, communication. When P.000 = 1, the start and stop of the SPD is decided by the SPD control terminals that is, once the SPD control terminals are connected, the SPD will run and be disconnected automatically. Then the automatic stop need no the additional start and stop instructions. When P.000 = 0, the SPD will not start and stop automatically, which need the additional start and stop instructions.

As the 0 section frequency, the P.188 just applies to the program running as the 0 section frequency.

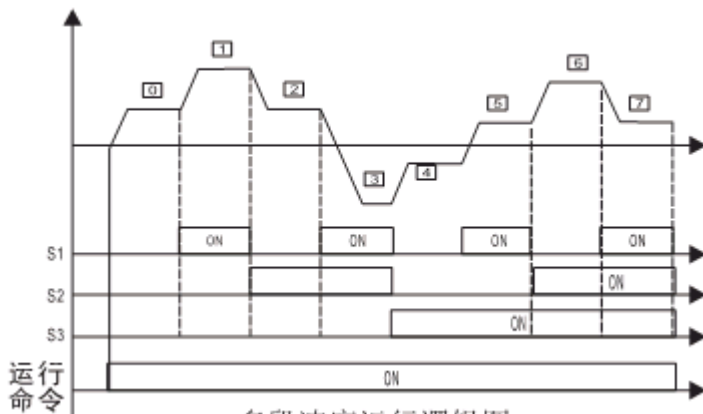

S1	OFF	ON	OFF	ON	OFF	ON
S2	OFF	OFF	ON	ON	OFF	ON
S3	OFF	OFF	OFF	OFF	ON	ON
Running section	0	1	2	3	4	7

Section VI. Fault Diagnosis & Solutions

AE200H is able to make full use of the device performance, while implementing effective protection. You may encounter following fault tips during operation, please control the following table analysis the possible causes, and rule out the fault.

If you encounter equipment damage or problems cannot be solved, please contact our 24-hour technical service hotline: 18038057788/18038011911

6-1 Fault alarm and solutions

AE200H series can not only make full use of equipment performance but also implement effective protection. AE200H series has some alarming information and protection function. Once fault occurs, protection function acts, output stops, inverter fault relay contact starts, and fault code is been displayed on the display panel. Before consulting the service department, the user can perform self-check according to the prompts of this chapter, analyze the fault cause and find out t solution. If the fault is caused by the reasons as described in the dotted frame, please consult the agents or our company directly.

Fault name	Acceleration over current
Panel display	Fault No.1= Err04(OC1)
Fault investigation	<ol style="list-style-type: none"> 1、 Acceleration time too short 2、 Improper manual torque boost or V/F curve 3、 Low voltage 4、 Inverter output loop grouded or short circuit 5、 Vector control mode without parameter identification 6、 Start the rotating motor 7、 Sudden load add in acceleration process 8、 Small type selection of inverter.
Fault countermeasures	<ol style="list-style-type: none"> 1、 Increase acceleration time 2、 Adjust manual torque boost or V/F curve 3、 Adjust voltage to normal range 4、 Eliminate external faults 5、 Parameter identification 6、 Select speed tracking start or restart after motor stop 7、 Cancel sudden added load 8、 Choose inverter of greater power level

Fault name	Deceleration over current
Panel display	Fault No.2= Err05(OC2)
Fault investigation	<ol style="list-style-type: none"> 1、 Inverter output loop grouded or short circuit 2、 Vector control mode without parameter identification 3、 Deceleration time too short 4、 Low voltage 5、 Sudden load add in deceleration process 6、 No braking unit and brake resistance installed
Fault	<ol style="list-style-type: none"> 1、 Eliminate external faults

Section VI. Fault Diagnosis & Solutions

countermeasures	<ol style="list-style-type: none"> 2、Parameter identification 3、Increase deceleration time 4、Adjust voltage to normal range 5、Cancel sudden added load 6、Install braking unit and brake resistance
-----------------	---

Fault name	Constant speed over current
Panel display	Fault No.3= Err06(OC3)
Fault investigation	<ol style="list-style-type: none"> 1、Inverter output loop grounded or short circuit 2、Vector control mode without parameter identification 3、Low voltage 4、Sudden load add in deceleration process 5、Small type selection of inverter
Fault countermeasures	<ol style="list-style-type: none"> 1、Eliminate external faults 2、Parameter identification 3、Adjust voltage to normal range 4、Cancel sudden added load 5、Choose inverter of greater power level

Fault name	Acceleration over voltage
Panel display	Fault No.4= Err07(OU1)
Fault investigation	<ol style="list-style-type: none"> 1、No braking unit and brake resistance installed 2、High input voltage 3、External force drive motor operation during acceleration process 4、Acceleration time too short
Fault countermeasures	<ol style="list-style-type: none"> 1、Install braking unit and brake resistance 2、Adjust voltage to normal range 3、Cancel external force or install brake resistance 4、Increase acceleration time

Fault name	Deceleration over voltage
Panel display	Fault No.5= Err08(OU2)
Fault investigation	<ol style="list-style-type: none"> 1、High input voltage 2、External force drive motor operation during deceleration process 3、Deceleration time too short 4、No braking unit and brake resistance installed
Fault countermeasures	<ol style="list-style-type: none"> 1、Adjust voltage to normal range 2、Cancel external force or install brake resistance 3、Increase deceleration time 4、Install braking unit and brake resistance

Fault name	Constant speed over voltage
Panel display	Fault No.6= Err09(OU9)
Fault investigation	<ol style="list-style-type: none"> 1、External force drive motor operation 2、High input voltage

Section VI. Fault Diagnosis & Solutions

Fault countermeasures	<ol style="list-style-type: none"> 1、 Cancel external force or install brake resistance 2、 Adjust voltage to normal range
-----------------------	---

Fault name	Control power supply fault
Panel display	Fault No.7= Err10(UV)
Fault investigation	1、 Input voltage is not within the specified range
Fault countermeasures	1、 Adjust voltage to normal range

Fault name	Inverter overload
Panel display	Fault No.8= Err12(OL2)
Fault investigation	<ol style="list-style-type: none"> 1、 Small type selection of inverter. 2、 Overload or motor stall
Fault countermeasures	<ol style="list-style-type: none"> 1、 Choose inverter of greater power level 2、 Reduce the load and check the motor and mechanical condition

Fault name	Motor overload
Panel display	Fault No.9= Err11(OL1)
Fault investigation	<ol style="list-style-type: none"> 1、 Small type selection of inverter 2、 Improper setup of P9.01 3、 Overload or motor stall
Fault countermeasures	<ol style="list-style-type: none"> 1、 Choose inverter of greater power level 2、 Set P9.01 correctly 3、 Reduce the load and check the motor and mechanical condition

Fault name	Output phase lack
Panel display	Fault No.10= Err14(SP0)
Fault investigation	<ol style="list-style-type: none"> 1、 Wiring between motor and inverter anomalies 2、 Inverter unbalanced 3-phase output 3、 Drive board anomalies 4、 Module anomalies
Fault countermeasures	<ol style="list-style-type: none"> 1、 Eliminate external loop faults 2、 Check 3-phase winding and eliminate faults 3、 For technical support

Fault name	Inverter overheating
Panel display	Fault No.11= Err16(OH2)
Fault investigation	<ol style="list-style-type: none"> 1、 Air duct block 2、 Fan damage 3、 High ambient temperature 4、 Module thermistor damage 5、 Inverter module damage
Fault countermeasures	<ol style="list-style-type: none"> 1、 Clean air dust 2、 Replace the fan

Section VI. Fault Diagnosis & Solutions

	<ul style="list-style-type: none"> 3、Reduce ambient temperature 4、Replace thermistor 5、Replace inverter module
--	---

Fault name	External equipment fault
Panel display	Fault No.12= Err17(EF)
Fault investigation	<ul style="list-style-type: none"> 1、Input external fault signal through S 2、Input external fault signal through IO
Fault countermeasures	<ul style="list-style-type: none"> 1、Reset operation

Fault name	Communication fault
Panel display	Fault No.13= Err18(CE)
Fault investigation	<ul style="list-style-type: none"> 1、Abnormal communication cable 2、Wrongly set communication expansion card P0.28 3、Wrongly set communication parameter PD group 4、Position machine operation anomalies
Fault countermeasures	<ul style="list-style-type: none"> 1、Check the communication cable 2、Set communication expansion card type correctly 3、Set communication parameter correctly 4、Check position machine cable

Fault name	Current inspection fault
Panel display	Fault No.14= Err19(IIE)
Fault investigation	<ul style="list-style-type: none"> 1、Drive board anomalies 2、Hall devices anomalies
Fault countermeasures	<ul style="list-style-type: none"> 1、Replace drive board 2、Replace hall devices

Fault name	Motor tuning fault
Panel display	Fault No.15= Err20(IIE)
Fault investigation	<ul style="list-style-type: none"> 1、Parameter identification process overtime 2、Wrongly set motor parameters
Fault countermeasures	<ul style="list-style-type: none"> 1、Check wire between inverter and motor 2、Set motor parameters correctly according to the nameplate

Fault name	EEPROM read & write fault
Panel display	Fault No.16= Err21(EEP)
Fault investigation	<ul style="list-style-type: none"> 1、EEPROM chip damage
Fault countermeasures	<ul style="list-style-type: none"> 1、Replace main control board

Fault name	PID feedback loss during operation fault
Panel display	Fault No.17= Err22(PIDE)

Fault investigation	1、PID feedback less than PA.26 set value
Fault countermeasures	1、Check PID feedback signal or set PA.26 to a proper value

6-2 Common fault and solutions

During the inverter using process, the following faults may occur. Please conduct simple fault analysis by referring to the methods below:

No.	Fault Phenomenon	Possible Cause	Solution
1	No display or error codes occur upon power-on	Abnormal input power supply, switch power supply fault of driven board, rectifier bridge damage, inverter buffer resistance damage, control board/keyboard fault, control board/driven board/keyboard disconnection	Check input power supply, bus voltage, re-plug 26 core cable, consult the manufacturer
2	Display“Err04” upon power-on	Poor contact between driven board and control board, device damage on control board, motor or motor cable short circuited, hall fault, grid undervoltage	Re-plug 26 core cable, consult the manufacturer
4	The inverter displays normally upon power-on, but “Err04” is displayed upon running and stops immediately	The fan is either damaged or blocked, peripheral control terminal short circuited	Replace the fan, exclude external short-circuit fault
5	Frequent fault report ERR14 =E14(module overheating)	The carrier frequency is set too high, the fan is damaged or the air duct is blocked, inverter internal components damaged	Replace the fan, clean air duct, reduce carrier frequency (P0.15) , consult manufacturer.
6	Motor no rotating after inverter power-on	Motor or motor cable, wrongly set inverter parameters(motor parameter), poor contact between driven board and control board, driven board fault	Replace the motor or remove the mechanical fault, check and reset the parameters, confirm connection between inverter and motor
7	S terminal invalid	Wrongly set inverter parameters, wrong external signal, SP and +24V jumper loosening, control board fault	Check and reset the P4 relevant parameters, reconnect cables, reconfirm PLC and +24V jumper, consult the manufacturer.
8	Closed loop vector control, motor speed cannot ascend	Encoder fault; PG card fault; drive board fault; encoder wrong connection or poor contact	Replace encoder&reconfirm connections; replace PG card; consult manufacturer.
9	The inverter frequently reports over current fault & over voltage fault	Motor wrongly set parameters, improper acc./dec. time, load fluctuation	Reset motor parameters or motor tuning, set proper acc./ dec.time, consult manufacturer.

The inverter may have the following fault conditions in the using process so please refer to the following methods for simple fault analysis:

No display for powering on: Checking whether the input power is consistent with the rated voltage of the frequency inverter with the multimeter. Please check and remove the power problems if any. Cheking whether the three-phase rectifier bridge intact. If the rectifier bridge has been exploded, please seek service.

The air switch trips off when it is powered on: checking whether thsre is ground or short circuit between the input power supply and eliminate the problem. Check whether the rectifier bridge has been damaged and please seek service if so.

The motor does not rotate after the frequency inverter is running:

Check whether there is a balanced three-phase voltage output between U, V and W. If so, the motor line or it is damaged, or the motor rotor is locked due to the mechanical reasons. Please exclude them.

U, V and W output voltage but three-phase is unbalanced, which should be that the frequency inverter drive board or output module is damaged so please seek service.

If there is no output voltage, the driver board or output module may be damaged, please seek service.

The powered-on frequency inverter is displayed normal and the power air switch tripped off after the operation: Check whether there is short circuit between the output module. If so please seek service.

Check whether there is a short circuit or grounding between the motor leads. If so, please exclude it. If the tripping operation occurs occasionally and the distance between the motor and the inverter is relatively far, please consider adding the AC reactor.

Caution:

- ※ After power off and within 5 minutes of charging indicator light(! CHARGE)out , please do not touch any spare parts inside the machine. The operator must use instrument to confirm capacitor discharge is completed, then could implement machine operation, or there may be electric shock risk!
- ※ Please do not touch the printed circuit board and IGBT etc internal device without electrostatic prevention measures. Or it could lead to the damage of components.

Section VII. Inspection & Maintenance

7-1 Inspection and Maintenance

Under normal working conditions, in addition to daily inspection, the frequency converter should be subject to regular inspection (for example inspection for overhaul or as specified but at an interval of at most six months). Please refer to the following table in order to prevent faults.

Daily	Regular	Check item	Check details	Method	Criterion
√		LED and OLED display	If any abnormal display	Visual check	As per use state
√	√	Fan	If any abnormal noise or vibration	Visual and audible check	No anomalies
√		Surrounding conditions	Temperature, humidity, dust content, harmful gas, etc.	Visual\ audible\ sensory check	As per 2-1 item
√		Input output voltage	If any abnormal input, output voltage	Measure R, S, T and U, V, W terminals	As per standard specifications
	√	Main circuit	Fasteners whether loose, if any signs showing overheat, discharging, or too high dust content, or the air piping is blocked	Check visually, tighten the fastenings, and clean the related parts	No anomalies
	√	Electrolytic capacitor	If any abnormal appearance	Check visually	No anomalies
	√	Current-conducting leads or blocks	Loose or not	Check visually	No anomalies
	√	Terminals	If the screws or bolts loose	Tighten the loose screws or bolts	No anomalies

“√” means need daily check or regularly check.

For inspection, do not disassemble or shake the parts without reason, or pull off the plug-in parts at random. Otherwise, the unit will not operate normally, or can not enter the mode of fault display, or causes faults of components or even parts of the main switch components IGBT module is damaged.

When needing measurement, the user should note that much different results will be gained possibly if the measuring is performed with different instruments. It is recommended that the input voltage be measured with pointer-type voltmeter, output voltage with rectification voltmeter, input and output current with tong-test ammeter, and power with electrically-driven wattmeter.

7-2 Regular replacement of the device

In order to ensure the operation reliability of the frequency converter, in addition to regular maintenance and inspection, all the parts suffering long-term mechanical wear should be replaced at a regular interval, which includes all cooling fans and the filtering capacitors of main circuits for energy buffer and interchange and PCBs. For continuous use under normal conditions, these parts can be replaced according to the following table and the operating environment, loads and the current state of frequency converter.

Part name	Standard replacement years
Cooling fan	1~3 years
Filtering capacitor	4~5 years
PCB (printed circuit board)	5~8 years

7-3 Storage

The following actions must be taken if the frequency converter is not put into use immediately after delivery to the user and need to keep well for the time being or stored for a long time:

- ※ Stored in a dry and adequately-ventilated place without dust and metal powder at the temperature specified in the specifications.
- ※ If the frequency converter is not put into use after one year, a charge test should be made, so as to resume the performance of the filtering capacitor of main circuit in it. For charging, a voltage regulator should be used to slowly increase the input voltage of the frequency converter until it reaches the rating, and the charge should last more than 1~2 hours. This test should be made at least once a year.
- ※ Don't perform breakdown test at random, for this test will cause shorter life of the frequency converter. The insulation test must be performed after the insulation resistance is measured with a 500-volt mega ohm and this value must not be less than 4MΩ.

7-4 Measuring and Judgment

- ※ If the current is measured with the general instrument, imbalance will exist for the current at the input terminal. Generally, differing by not more than 10% is normal. If it differs by 30%, inform the factory to replace the rectification bridge, or check if the error of three-phase input voltage is above 5V.
- ※ If the three-phase output voltage is measured with a general multi-meter, the read data is not accurate due to the interference of carrier frequency and only for reference.

7-5 Safety Precaution

- ※ Only specially trained persons are allowed to disassembly,replace the drive components.
- ※ Before the inspection and maintenance,inverter must be confirmed at least 10 minutes after power off or charged(CHARGE) light is off,otherwise there is risk of electric shock.
- ※ Avoid metal parts leaving in the drive, or it may result in equipment damage.

Appendix I DN5RS485 Card & RS485 Communication Protocol

I-1 DN5RS485 card

DN5RS485 card produced by AE200H is used with AE200H series inverter as RS485 communication card. It contains the following resources:

Item	Specification	Description
Input terminal	2-channel digital signal input 4	S7~S8
Output terminal	1-channel relay signal output	TA2,TB2,TC2
	1-channel digital signal output	DO2
Communication	RS485 communication port	Support Modbus-RTU protocol (Appendix I: AE200H Monbus communication protocol)

I-2 Mechanical installation and control terminal function description

Installation, appearance, control terminal function definitions, jumper, respectively, see Appendix I, Figure 1, Table 1, Table 2. Please install the inverter after complete power outage.

- 1) Align DN5RS485 card and inverter control board's expansion card interface and the positioning holes.
- 2) Fix the screw.

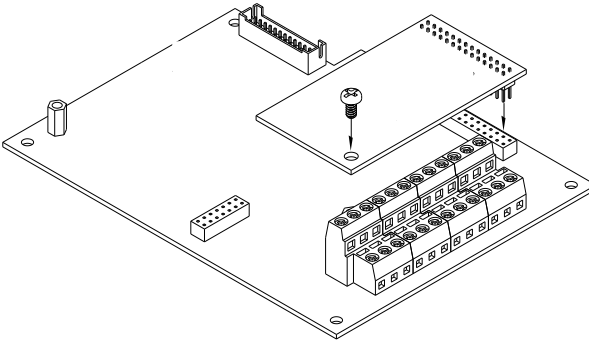

Fig1 DN5RS485 card assembly schematic diagram

Table 1 Control terminal function description

Category	Terminal symbol	Terminal name	Function description
Function digital input terminal	S7-SP1	S7	1.Optocoupler isolation,compatible with bipolar input 2.Input impedance: 4.7kΩ 3. Voltage range when level input: 9~30V
	S8-SP1	S8	
Digital output	DO2-COM	DO2	Optocoupler isolation, bipolar open collector electrode output voltage: 0V~24V output current range: 0mA~50mA
Relay output (RELAY2)	TA2-TB2	Normally closed terminal	Contact drive capability: AC250V, 3A, COSφ=0.4. DC30V, 1A

	TA2-TC2	Normally open terminal	
RS-485 communication	485+/485-	Communication interface terminal	Modbus-RTU protocol communication input, output signal terminal, isolation input

Table 2 Jumper description

Jumper number	Description
J1	SP1 connection mode selection
J2	RS485 Termination resistor selection

I-3 Communication protocol

I-3-1 Protocol content

The serial communication protocol defines the information content and format of the use of the transmission in serial communication. Including: the host polling (or broadcast) format、host encoding methods.Concent including: require action of the function code, data transmission and error checking and so on. Slave machine's response is the same structure, including: action confirmation, return data and error checking. Slave error occurred when receiving information, or can not do what the host request action, it will organize a fault message as the response back to the host computer.

Application mode:

The inverter accessing with “ single main multi-slave” PC/PLC control network which equipped with RS232/RS485 bus.

Bus structure:

(1)Interface mode

RS232/RS485 hardware interface

(2)Transmission mode

Asynchronous serial, half-duplex transmission. At the same time host and slave computer can only permit one to send data while the other can only receive data. Data in the process of serial asynchronous communication is in the message format and sent one frame by one frame.

(3)Topological mode

In single-master system, the setup range of slave address is 1 to 247. Zero refers to broadcast communication address. The address of slave must is exclusive in the network. That is one condition of one slave machine.

I-3-2 Protocol Description

AE200H series inverter communication protocol is an asynchronous serial master-slave Modbus communication protocol, only one device in the network (master) to establish protocol (known as the "query / command"). Other device (slave) can only provide data response to the host query / command, or make the appropriate action according to the host query / command. Host refers to a personal computer (PC), industrial control equipment, or programmable logic controller (PLC), etc. The slave indicates AE200H inverter. Host can not only communicate separately with the slave, but also broadcast messages to the lower machine. For separate access to the host query / command, the slave should return a message (called the response), and for broadcast information issued

by host machine , feedback needs not to be responded to the host.

Communication data structure AE200H series inverter Modbus protocol communication data format is as follows: using RTU mode, messages are sent at least at interval of 3.5 bytes times pause. In a variety of bytes in the network baud rate of time, this could be most easily achieved (see below T1-T2-T3-T4 shown). The transmission of a domain is the device address.

Transmission characters are hexadecimal 0...9, A...F. Network equipment continue to detect the network bus, including a pause interval of time. When the first field (the address field) is received, each device decodes it to determine whether sent to their own. At least 3.5 bytes times pause after the last transmitted character, a calibration of the end of the message. A new message may start after this pause.

The entire message frame must be used as a continuous stream. If the pause time frame prior to the completion of more than 1.5 byte times, the receiving device will refresh the incomplete message and assumes that the next byte will be the address field of a new message. Similarly, if a new message starts in less than 3.5 bytes times following the previous message, the receiving device will consider it a continuation of the previous message. This will set an error, as the value in the final CRC field will not be valid for the combined messages. A typical message frame is shown below.

RTU frame format:

START	3.5-character time
Slave address ADDR	Communication address: 1-247
Command code CMD	03: Read slave parameters; 06: Write slave parameters
DATA(N-1)	Function code parameter address,function code parameter number,function code parameter value,etc.
DATA(N-2)	
.....	
DATA0	
CRC CHK low order	Detection value: CRC value.
CRC CHK high order	
END	At least 3.5-character time

CMD(command instructions) and DATA(material words description)

Command code: 03H, reads N words(There are 12 characters can be read at most). For example: the inverter start address F0.02 of the slave machine address 01 continuously reads two consecutive values.

Host command

ADR	01H
CMD	03H
Start address high order	F0H
Start address low order	02H
Register number high order	00H
Register number low order	02H
CRC CHK low order	CRC CHK values to be calculated
CRC CHK high order	

Slave response

PD.05=0:

ADR	01H
CMD	03H
Byte number high order	00H
Byte number low order	04H
Data P002H high order	00H
Data P002H low order	00H
Data P003H high order	01H
CRC CHK low order	CRC CHK values to be calculated
CRC CHK high order	

PD.05=1:

ADR	01H
CMD	03H
Byte number	04H
Data F002H high order	00H
Data F002H low order	00H
Data F003H high order	00H
Data F003H low order	01H
CRC CHK low order	CRC CHK values to be calculated
CRC CHK high order	

Command code: 06H write a word

For example: Write 5000 (1388H) into F00AH which slave address is 02H.

Master command information

ADR	02H
CMD	06H
Data address high order	F0H
Data address low order	0AH
Data content high order	13H
Data content low order	88H
CRC CHK low order	CRC CHK values to be calculated
CRC CHK high order	

Slave response

ADR	02H
CMD	06H
Data address high order	F0H
Data address low order	0AH
Data content high order	13H
Data content low order	88H
CRC CHK low order	CRC CHK values to be calculated
CRC CHK high order	

I-4 Cyclical Redundancy Check:

Cyclical Redundancy Check—CRC mode: CRC(Cyclical Redundancy Check) is in RTU frame format, message contains an error-checking field that is based on a CRC method. The CRC field checks the contents of the entire message. The CRC field is two bytes, containing a 16-bit binary value. The CRC value is calculated by the transmitting device, which appends the CRC to the message. The receiving device recalculates a CRC during receipt of the message, and compares the calculated value to the actual value it received in the CRC field. If the two values are not equal, an error results. The CRC is started by 0xFFFF. Then a process begins of applying successive 8-bit bytes of the message to the current contents of the register. Only the eight bits of data in each character are used for generating the CRC. Start and stop bits, and the parity bit, do not apply to the CRC.

During generation of the CRC, each eight-bit character is exclusive XOR with the register contents. Then the result is shifted in the direction of the least significant bit (LSB), with a ZERO filled into the most significant bit (MSB) position. The LSB extracted and examined. If the LSB was 1, the register then exclusive XOR with a preset, fixed value. If the LSB was 0, no exclusive XOR takes place. This process is repeated until 8 shifts have been performed. After the last (8) shift, the next eight-bit byte is exclusive XOR with the register's current value, and the process repeats for 8 more shifts as described above. The final contents of the register, after all the bytes of the message have been applied, is the CRC value.

When CRC appended to the message, the low byte is appended first, and then the high byte.

CRC calculation program:

```
unsigned int cal_crc16 (unsigned char *data, unsigned int length)
{
    unsigned int i,crc_result=0xffff;
    while(length-->0)
    {
        crc_result^=*data++;
        for(i=0;i<8;i++)
        {
            if(crc_result&0x01)
                crc_result=(crc_result>>1)^0xa001;
            else
                crc_result=crc_result>>1;
        }
    }
    crc_result=((crc_result&0xff)<<8)|(crc_result>>8);
    return(crc_result);
}
```

I-5 Communication parameter address

The chapter is about communication contents, it's used to control the inverter operation, the status of the inverter and related parameter setup. Read and write function code parameters (Some function codes are not able to be changed, only for the manufacturer use.). The mark rules of function code parameters address:

The group number and mark of function codes are parameter address for indication rules.

High byte: 00~01;Low byte: 00~FF

For example: P3.12, the address indicates F30C

Caution:

Group PF: Parameters could not be read or be modified.

Group U: Parameters could be read but not be modified.

Some parameters can not be changed during operation, some parameters regardless of the kind of state the inverter in, the parameters can not be changed. Change the function code parameters, pay attention to the scope of the parameters, units, and relative instructions.

Besides, if EEPROM is frequently stored, it will reduce the service life of EEPROM. In some communication mode, function code needn't to be stored as long as changing the RAM value.

Group P: to achieve this function, change high order F of the function code address into 0.

Group A: to achieve this function, change high order A of the function code address to be 4.

Corresponding function code address are indicated below:

High byte: 00~01 Low byte: 00~FF

For example:

Function code P.007 can not be stored into EEPROM, address indicates to be 030C, function code A0-05 can not be stored in EEPROM, address indicates to be 4005; This address can only act writing RAM, it can not act reading, when act reading, it is invalid address. For all parameters, command code 07H can be used to achieve this function.

Stop/running parameter:

Parameter addr.	Parameter description
3000H	Setup frequency
3001H	Running frequency
3002H	Output current
3003H	Output voltage
3004H	Running speed
3005H	Output power
3006H	Output torque
3007H	Bus voltage
3008H	PID Given value
3009H	PID Feedback
300AH	Terminal input status
300BH	Terminal output status

Communication fault response:

300CH	Analog quantity FV
300DH	Analog quantity FI
300EH	Current number of segments
300FH	Current count value

Caution:

The communication setup value is percentage of the relative value, 10000 corresponds to 100.00%, -10000 corresponds to -100.00%. For data of dimensional frequency, the percentage value is the percentage of the maximum frequency. For data of dimensional torque, the percentage is P2.10, A2.48, A3.48, A4.48 (Torque upper digital setup, corresponding to the first, second, third, fourth motor).

Control command input to the inverter (write-only)

Command word address	Command function
1000H	0001H: Forward operation
	0002H: Reverse operation
	0003H: Forward jog
	0004H: Reverse jog
	0005H: Free stop
	0006H: Speed-down stop
	0007H: Fault reset

Read inverter status: (read-only)

Status word address	Status word function
1001H	0001H: Forward operation
	0002H: Reverse operation
	0003H: Standby
	0004H: Fault

Communication fault information describing data (fault code):

Communication fault address	Fault function description
5001H	00H: No fault
	01H: Command code error
	02H: Invalid address
	06H: Inverter busy
	10H: Password error
	11H: CRC check error
	03H: Invalid parameter
	12H: Parameter change invalid
	13H: The system is locked
	14H: Invalid number of data

Communication fault response:

START	T1-T2-T3-T4
ADDR	01H

CMD	06H
Fault return High byte	50H
Fault return low byte	01H
Error High byte	00H
Error low byte	05H
CRC CHK High byte	09H
CRC CHK low byte	09H
END	T1-T2-T3-T4

ASCII response:

START	“.”
ADDR	“0”
	“1”
CMD	“0”
	“6”
Fault return High byte	“5”
	“0”
Fault return low byte	“0”
	“1”
Error High byte	“0”
	“0”
Error low byte	“0”
	“5”
LRC CHK Hi	“A”
LRC CHK Lo	“3”
END Lo	ER
END Hi	LF

Meaning of error code:

Error	Discription
1	Command code error

ASCII response:

2	Invalid address
3	Invalid parameter
4	Reserve
5	Reserve
6	Inverter busy
7	Reserve
8	Reserve
9	Reserve
10	Password error
11	CRC check error
12	Parameter change invalid
13	The system is locked
14	Invalid number of data

485 Communication Parameter Setting Procedures:

P.000=2; (Communication command channel)

P.003=6; (Communication given frequency)

P.004=100 (Maximum communication frequency)

P.142=1 (Local communication address)

P.143=3 (Baud rate:9600)

P.144=1 (verification 8E1)

Appendix II Multi-function Card DN5PC1

II-1 Outline

DN5PC1 card produced by AE200H is the multi-function IO expansion card matching the AE200H series inverter.

It contains the following resources:

Item	Specification	Description
Input terminal	4-channel digital signal input	S7-S10
	1-channel analog voltage signal input	Support -10V~10V voltage input signal
Output terminal	1-channel relay signal output	TA2,TB2,TC2
	1-channel digital signal input	DO2
Communication	RS-485 communication port	Support Modbus-RTU communication protocol (refer to Appendix I: AE200H Monbus communication protocol)
	CAN communication port	Support CANlink communication protocol

II-2 Mechanical installation and control terminal function description

Installation, appearance, control terminal function definitions, jumper, respectively, see Appendix II, Figure 1, Table 1, Table 2.

- 1)Please install the inverter when completely powered down
- 2)Align DN5PC1 card and inverter control board's expansion card interface and the positioning holes
- 3)Fix the screw.

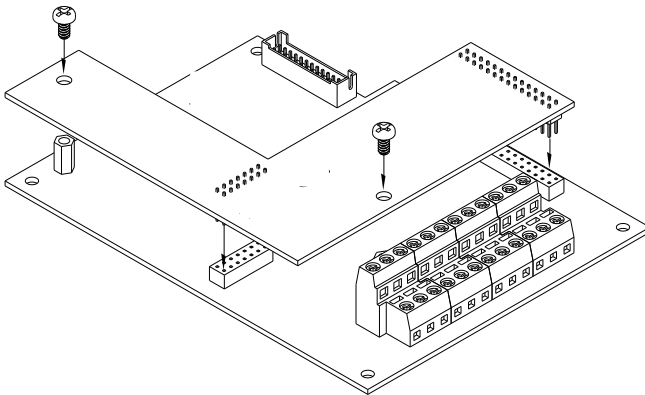

Figure 1 DN5PC1card installation schematic diagram

Table1 Control terminal function description

Category	Terminal symbol	Terminal name	Function description
Power	+24V-COM	+24V external power supply	Output +24V power supply, normally used as digital inputs and outputs terminal's working power supply and external sensor power supply maximum output current: 200mA
	SP1	Digital input power terminal	SP1 and +24 V has been connected with jumper J8 before out of factory, when to use an external power supply, SP1 needs to be connected with an external power supply, and must take down the J8.
Analog input	AI3x-PGND	Analog input terminal 3x	1.Set the same parameter as the control panel AI3 , jumper different 2.Optocoupler isolation input, accepts differential input voltage and temperature sense detecting resistor input 3.The input voltage range: DC-10V ~ 10V 4.PT100, PT1000 temperature sensor 5.Use DIP switch S1 to determine input methods, multi functions can not be used at the same time.
Function digital input terminal	S7-SP1	Digital input 7	1.Optocoupler isolation, compatible with a bipolar input 2. Input impedance: 4.7kΩ 3. Voltage range when level input: 9~30V
	S8-SP1	Digital input 8	
	S9-SP1	Digital input 9	
	S10-SP1	Digital input10	
Analog output	AO2-GND	Analog output 2	1. Output voltage specification: 0V~10V 2. Output current specification: 0mV~20mV
Digital output	DO2-COM	Digital output 2	Optocoupler isolation, bipolar open collector output voltage : 0V~24V output current range: 0mA~50mA
Relay output(RELAY2)	TA2-TB2	Normally closed terminal	Contact drive capability: AC250V,3A,COSφ=0.4. DC30V,1A
	TA2-TC2	Normally open terminal	
RS-485 communication	485+/485-	Communication interface terminal	Modbus-RTU protocol communication input, output signal terminal, isolated input
CAN communication	CANH/CANL	Communication interface terminal	CANlink protocol communication input terminal, isolated input

Table 2 Jumper description

Jumper no.	Description
S1	SP1 connection mode selection
S2	AO2 Output selection-voltage,current
S3	CAN Termination resistor selection
S4	RS485 Termination resistor selection
S5	AI3、PT100、PT1000 function selection

Appendix III Programmable Multi-function Expansion Card DN5PLC1

III-1 Outline

DN5PLC1 User programmable card is an expansion card of integrated PLC function. Users can install the expansion card to make AE200H series inverter support the PLC (programmable) function. Seamless connectivity of the card and the inverter can access the functionality of the inverter common code, you can also access some special variables inside the inverter to make it more advantages than a simple combination of PLC and inverter.

DN5PLC1 programming environment is been used under the AE200H's PLC programming status, meanwhile compatible to other brand PLC programming. And this card also integrates the following extended IO and general communication interface :

Item	Specification	Description
Input terminal	10-channel digital signal input	Ix1~Ix10 PLC programmable input port
	1-channel analog voltage signal input	With isolation, support -10V~10V voltage input signal
Output terminal	6-channel digital signal output	Ox1~Ox6 PLC programmable output port
	1-channel relay signal output	TA2,TB2,TC2
Communication	RS-485 communication interface	Free port(RS485)
		PPI(RS485)

III-2 Mechanical installation and control terminal function description

Installation, appearance, control terminal function definitions, jumper, respectively, see Appendix III, Figure 1, Table 1, Table 2.

- 1)Please install the inverter when completely powered down
- 2)Align DN5PLC1 card and inverter control board's expansion card interface and the positioning holes
- 3)Fix the screw

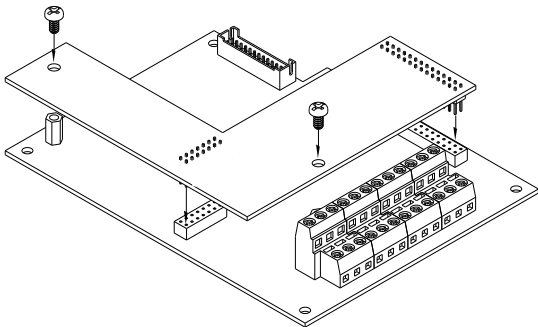

Figure1 DN5PLC1card installation schematic diagram

Table 1 Control terminal function description:

Category	Terminal symbol	Terminal name	Function description
Power supply	+24V-COM	+24V external power supply	Output +24 V power supply, normally used as digital inputs and outputs terminal's working power supply and external sensor power supply maximum output current: 200mA
	SP1	Digital input power terminal	SP1 and +24 V has been connected with jumper J8 before out of factory, when using an external power supply, SP1 needs to be connected with an external power supply, and must take down the J8.
Analog input	AI3x-PGND	Analog input terminal 3	1.Optocoupler isolation input, accepts differential input voltage and temperature sense detecting resistor input 2.the input voltage range: DC-10V ~ 10V 3.Input current range: DC-20mA~20mA 4. PTC, PT100 temperature sensor 5.using DIP switch S1 determine input methods, variety of functions can not be used at the same time.
Functional digit input terminal	Ix1-SP1	Programmable input1	Optocoupler isolation, compatible with a bipolar input; Input impedance : 4.7kΩ; Voltage range when level input: 9~30V
	Ix2-SP1	Programmable input 2	
	Ix3-SP1	Programmable input 3	
	Ix4-SP1	Programmable input 4	
	Ix5-SP1	Programmable input 5	
	Ix6-SP1	Programmable input 6	
	Ix7-SP1	Programmable input 7	
	Ix8-SP1	Programmable input 8	
	Ix9-SP1	Programmable input 9	
	Ix10-SP1	Programmable input10	
Functional digit output terminal	Ox1-SP1	Programmable output 1	Optocoupler isolation, bipolar open collector output voltage: 0V~24V output current range: 0mA~50mA
	Ox2-SP1	Programmable output 2	
	Ox3-SP1	Programmable output 3	
	Ox4-SP1	Programmable output 4	
	Ox5-SP1	Programmable output 5	
	Ox6-SP1	Programmable output 6	
Relay output(RELAY2)	TA2-TB2	Normally closed terminal	Contact drive capability: AC250V,3A,COSφ=0.4。 DC30V,1A
	TA2-TC2	Normally open terminal	
Free port(RS485)	485+/485-	485communication interface terminal	Baud rate 1.2k~115.2k
	GND	485communication isolation power	
PPI(RS485)	CN1	User program download	Baud rate 9.6, 19.2 and 187.5k

Table 2 Jumper description:

Jumper	Description
S1	SP1 connection mode selection
S2	RUN/STOP selection
S3	AI3 input selection-voltage, current
S4	Free port RS485 termination resistor selection
S5	AI3、PT100、PT1000 function selection (multi functions can not be used at the same time)

Appendix IV Common Encoder Expansion Card

(Suitable for all series products)

IV-1 Outline

AE200H equipped with a variety of common encoders expansion card (PG card), as the optional spares, which is the required spares for the inverter's closed-loop vector control , according to the output form of the encoder to select the appropriate PG card, specific Models are as follows:

Optional spares	Description	Others
DN5PG1	Differential input PG card, without the sub-frequency output OC input PG card, without the sub-frequency output 5V, 12V voltage optional, offer voltage info and pulse input mode when you order.	Terminal connection
DN5PG3	UVW differential input PG card, without the sub-frequency output 5V voltage	DB15 female seat
DN5PG4	Rotary inverter PG card	DB9 female seat
DN5PG5	OC input PG card, 1: 1 sub-frequency output 5V, 12V voltage optional, offer voltage info when order.	Terminal connection

IV-2 Mechanical installation and control terminal function description

Installation, appearance, control terminal function definitions, jumper, respectively, see Appendix IV, Figure 1, Table 1.

- 1)Please install the inverter when completely powered down
- 2)Please install or take down the PG card when completely powered down;
- 3)14-pin female should be connected to the expansion card (note that the installation side are up to the vacancies), tighten the mounting hole screws.

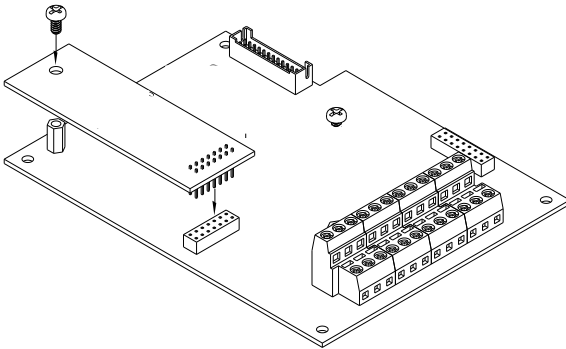

Figure 1 DN5PG card installation schematic diagram.

Each encoder expansion card specification & connection terminal signal definitions are shown as follows:

Table 1 Specification and connection terminal signal definition

Differential PG card (DN5PG1)		
DN5PG1 specification		
User interface	Oblique plug terminal block	
Space	3.5mm	
Screw	Flatheaded screw	
Plug	No	
Wire guage	16-26AWG	
Maximum speed	500kHz	
Input differential signal amplitude	≤7V	
DN5PG1 connection terminal signal definition		
Item	Mark	Description
1	+5V	Output 5V/100mA power to the external side, other power form need to be output from the external side. Note that PG card jumper voltage mode selected should be marked when order.
2	GND	Power ground
3	A+	Encoder output A Signal: positive
4	A-	Encoder output A Signal: positive
5	B+	Encoder output B Signal: positive
6	B-	Encoder output B Signa: negative
7	Z+	Encoder output Z Signal: positive
8	Z-	Encoder output Z Signal: negative
UVW differential PG card		
DN5PG3 specification		
User interface	DB15 female seat	
Plug	Yes	
Wire guage	>22AWG	
Maximum speed	500kHz	
Input differential signal amplitude	≤7V	
DN5PG3 terminal description		
Item	Mark	Description
1	A+	Encoder output A Signal: positive
2	A-	Encoder output A Signal: negative
3	B+	Encoder output B Signal: positive
4	B-	Encoder output B Signal: negative
5	Z+	Encoder output Z Signal: positive
6	Z-	Encoder output Z Signal: negative
7	U+	Encoder output U

Appendix IV Common Encoder Expansion Card

		Signal: positive
8	U-	Encoder output U Signal: negative
9	V+	Encoder output V Signal: positive
10	V-	Encoder output V Signal: negative
11	W+	Encoder output W Signal: positive
12	W-	Encoder output W Signal: negative
13	+5V	Supply external power 5V/50mA
14	COM	Power ground
15	-	
Rotary transformer PG card(DN5PG4)		
DN5PG4 specification		
User interface	DB9 female seat	
Plug	Yes	
Wire guage	>22AWG	
Resolution	12 bit	
Excitation frequency	10kHz	
VRMS	7V	
VP-P	3.15±27%	
DN5PG4 terminal description		
Item	Sign	Description
1	EXC1	Rotary transformer excitation negative
2	EXC	Rotary transformer excitation positive
3	SIN	Rotary transformer feedback SIN positive
4	SINLO	Rotary transformer feedback SIN negative
5	COS	Rotary transformer feedback COM positive
6	-	
7	-	
8	-	
9	COSLO	Rotary transformer feedback COS negative
OC PG card(DN5PG5)		
DN5PG5 specification		
User interface	Oblique plug terminal block	
Space	3.5mm	
Screw	Platheaded screw	
Plug	No	
Wire guage	16-26AWG	
Maximum speed	100KHz	
DN5PG5 terminal description		
Item	Mark	Description
1	A	Encoder output A signal
2	B	Encoder output B signal
3	Z	Encoder output Z signal
4	12V	Output 12V/50mA power to the external side, other power form need to be output

Appendix IV Common Encoder Expansion Card

		from the external side. Note that PG card jumper voltage mode selected should be marked when order.
5	COM	Power ground
6	COM	Power ground
7	A1	PG card1: 1 feedback output A signal
8	B1	PG card 1: 1 feedback output B signal
9	PE	Screen cable terminal

Product Feedback

Dear users:

Thank you for your interest and purchasing of AE200H products!

AE200H adheres to the "user-centric", based on customer demand, and offering full customer service to enhance customer satisfaction.

In order to provide better service for you, we hope to be able to timely access to your personal information and your purchased AE200H products information . We hope to learn about your present and future demand for AE200H products as well as your valuable feedback of the products. In order to help you get our service faster and more convenient, please contact our engineers for more information feedback.

- 1) Download the product manual you need.
- 2) Read and download all kinds of product technical information, such as operation instruction, product specification, features, FAQ, etc.
- 3) Application cases.
- 4) Technical consultation, on-line feedback
- 5) Feedback product information and customer requirement information by e-mail.
- 6) Inquiry for the latest products, obtain various types of warranty and extend additional service, etc.